



# Numerical Study of Soliton Solutions of KdV, Boussinesq, and Kaup–Kuperschmidt Equations Based on Jacobi Polynomials

<sup>1</sup>Khadijeh Sadri & <sup>2</sup>Hamideh Ebrahimi

<sup>1</sup> Young Researchers and Elite Club  
Rasht Branch – Islamic Azad University  
Rasht, Iran  
[kh.sadri@uma.ac.ir](mailto:kh.sadri@uma.ac.ir)

&

<sup>2</sup> Department of Mathematics  
Rasht branch – Islamic Azad University  
P. O. Box 41335-3516  
P. C. 4147654919, Rasht, Iran  
[h.ebrahimi@iaurasht.ac.ir](mailto:h.ebrahimi@iaurasht.ac.ir)

Received: March 26, 2016; Accepted: March 20, 2017

## Abstract

In this paper, a numerical method is developed to approximate the soliton solutions of some nonlinear wave equations in terms of the Jacobi polynomials. Wave are very important phenomena in dispersion, dissipation, diffusion, reaction, and convection. Using the wave variable converts these nonlinear equations to the nonlinear ODE equations. Then, the operational Collocation method based on Jacobi polynomials as bases is applied to approximate the solution of ODE equation resulted. In addition, the intervals of the solution will be extended using an rational exponential approximation (REA). The KdV, Boussinesq, and Kaup–Kuperschmidt equations are studied as the test examples. Finally, numerical computation of the conservation values shows the effectiveness and stability of the proposed method.

**Keywords:** KdV Equation; Boussinesq Equation; Kaup–Kuperschmidt; Equation; Jacobi Polynomials; Rational Exponential Approximation; Conservation Values

**MSC 2010 No.:** 33C45, 33Q51, 33Q53, 65M12, 65M70, 65Z05

## 1. Introduction

Nonlinear evolution equations are widely used as models to describe complex physical phenomena in various fields of sciences, especially in fluid mechanics, solid state physics, plasma physics, plasma waves, and biology. For this reason, finding the exact or approximate solutions of these equations is very important. One of the basic physical problems for these models is to obtain their traveling solutions. In recent years, a variety of effective analytical and semi analytical methods have been used for nonlinear PDEs, such as tanh–coth method (cf. Wazwaz (2007), Wazwaz (2008a), Wazwaz (2008b)), Exp–function method (cf. Ravi et al. (2017), Ekici et al. (2017)), Dai et al. (2009), Hirota bilinear method (cf. Wazwaz (2010), Wazwaz (2008c), Wazwaz (2008d)),  $G'/G$ –expansion method (cf. Manafian et al. (2017), Mohyud–Din and Bibi (2017), Kabir et al. (2011), Ekici (2017), Shehata (2010), Zheng et al. (2015)), Adomian decomposition method (cf. Achouri et al. (2009)), Variational iteration method (cf. Lu (2011)), Differential transform method (cf. Mohamed and Gepreel (2017), Yu et al. (2016), Yang et al. (2016)), and many others. The specific cases of the Jacobi polynomials have been applied to solve the nonlinear equations. For example, Bhrawy et al. have presented a new Legendre spectral collocation method for fractional Burgers equations (cf. Behrawy et al. (2015)). In Doha (2014), the authors used Jacobi–Gauss–Lobatto collocation method for the numerical solution of  $(1+1)$ – nonlinear Schrödinger equation. Also, Bhrawy (2014) has presented an pseudospectral approximation based on Jacobi polynomials for generalized Zakharov system. Two spectral tau algorithms based on Jacobi polynomials have been applied to solve multi–term time–space fractional partial differential equations and time fractional diffusion–Wave equations (cf. Bhrawy et al. (2014), Bhrawy and Zaky (2015)).

In this current paper, we try to handle the Jacobi polynomials in a different way for achieving more desirable results. Since the existing analytical methods are restricted for obtaining exact solutions of nonlinear wave equations, we interested in the numerical solution of this kind of nonlinear problems. The numerical methods are of great importance for approximating the solutions of nonlinear PDEs, especially when the nonlinear differential equation under consideration faces difficulties in obtaining its exact solution. In this case, we usually use an appropriate and efficient numerical method. The aim of this paper is to use the wave variable and convert the nonlinear PDE to the corresponding nonlinear ODE. The resulting ODE will be solved by operational Jacobi Collocation method. For this purpose, integral operational matrices based on Jacobi polynomials will be constructed. Thus, the principle nonlinear equation is transformed by a system of nonlinear algebraic equations which is solved by well known Newton iteration method and determined unknown coefficients. It should be mentioned that the  $(N + 1)$  roots of Jacobi polynomials  $P_{N+1}^{(\alpha,\beta)}(x)$  are considered as the collocation nodes. Since the approximate solutions are in the form of polynomials, they are unable to express the soliton nature of the exact solutions. For this reason, the approximate solution obtained will be improved using a rational exponential approximation (REA). Consequently, the improved solutions coincide with the soliton solutions and the interval of convergence is extended. The proposed scheme is applied for special cases of KdV, Boussinesq, and Kaup–Kuperschmidt equations as follows Wazwaz (2009):

*i)* KdV equation:

$$u_t - 6uu_x + u_{xxx} = 0, \quad (1)$$

ii) Boussinesq equation:

$$u_{tt} - u_{xx} - 3(u^2)_{xx} - u_{xxxx} = 0, \quad (2)$$

iii) Kaup–Kuperschmidt equation:

$$u_t - u_{xxxxx} + 20uu_{xxx} + 50u_xu_{xx} - 80u^2 = 0. \quad (3)$$

The remainder of this paper is organized as follows: The Jacobi polynomials, some of their properties, and the operational matrices of integration and product are introduced in Section 2. Afterwards, Section 3 is devoted to describe the proposed scheme. The proposed method for solving the nonlinear wave equations will be applied in Section 4. For this purpose, the Equations (1)–(3) are considered as the illustrative examples. A conclusion is presented in Section 5.

## 2. Jacobi polynomials and their operational matrices

The well-known Jacobi polynomials are defined on the interval  $[-1, 1]$ , constitute an orthogonal system with respect to the weight function  $w^{(\alpha,\beta)}(x) = (1-x)^\alpha (1+x)^\beta$ , and can be determined with the following recurrence formula:

$$\begin{aligned} P_{i+1}^{(\alpha,\beta)}(x) &= A(\alpha, \beta, i) P_i^{(\alpha,\beta)}(x) + x B(\alpha, \beta, i) P_i^{(\alpha,\beta)}(z) \\ &\quad - D(\alpha, \beta, i) P_{i-1}^{(\alpha,\beta)}(x), \quad i = 1, 2, \dots, \end{aligned} \quad (4)$$

where

$$\begin{aligned} A(\alpha, \beta, i) &= \frac{(2i + \alpha + \beta + 1)(\alpha^2 - \beta^2)}{2(i+1)(i + \alpha + \beta + 1)(2i + \alpha + \beta)}, \\ B(\alpha, \beta, i) &= \frac{(2i + \alpha + \beta + 2)(2i + \alpha + \beta + 1)}{2(i+1)(i + \alpha + \beta + 1)}, \\ D(\alpha, \beta, i) &= \frac{(i + \alpha)(i + \beta)(2i + \alpha + \beta + 2)}{(i+1)(i + \alpha + \beta + 1)(2i + \alpha + \beta)}, \end{aligned}$$

and

$$P_0^{(\alpha,\beta)}(x) = 1, \quad P_1^{(\alpha,\beta)}(x) = \frac{\alpha + \beta + 2}{2}x + \frac{\alpha - \beta}{2}.$$

The orthogonality condition of Jacobi polynomials is

$$\int_{-1}^1 P_j^{(\alpha,\beta)}(x) P_k^{(\alpha,\beta)}(x) w^{(\alpha,\beta)}(x) dx = h_k \delta_{jk},$$

where

$$h_k = \frac{2^{\alpha+\beta+1} \Gamma(k + \alpha + 1) \Gamma(k + \beta + 1)}{(2k + \alpha + \beta + 1) k! \Gamma(k + \alpha + \beta + 1)}.$$

The analytic form of Jacobi polynomials is given by Szego (1939),

$$\begin{aligned} P_i^{(\alpha,\beta)}(x) &= \sum_{k=0}^i \frac{(-1)^{i-k} \Gamma(i + \beta + 1) \Gamma(i + k + \alpha + \beta + 1)}{\Gamma(k + \beta + 1) \Gamma(i + \alpha + \beta + 1) (i-k)! k!} \left( \frac{1+x}{2} \right)^k, \\ & \quad i = 0, 1, \dots \end{aligned} \quad (5)$$

A continuous function  $u(x)$ , square integrable in  $[-1, 1]$ , can be expressed in terms of the Jacobi polynomials as,

$$u(x) = \sum_{j=0}^{\infty} C_j P_j^{(\alpha,\beta)}(x), \tag{6}$$

where the coefficients  $C_j$  are given by

$$C_j = \frac{1}{\theta_j} \int_{-1}^1 u(x) P_j^{(\alpha,\beta)}(x) w^{(\alpha,\beta)}(x) dx, \quad j = 0, 1, \dots$$

In practice, only the first  $(N + 1)$  terms the Jacobi polynomials are considered. Therefore, one has

$$u_N(x) = \sum_{j=0}^N C_j P_j^{(\alpha,\beta)}(x) = \Phi^T(x) C = C^T \Phi(x), \tag{7}$$

where the vectors  $C$  and  $\Phi(x)$  are given by

$$C = [C_0, C_1, \dots, C_N]^T, \quad \Phi(x) = [P_0^{(\alpha,\beta)}(x), P_1^{(\alpha,\beta)}(x), \dots, P_N^{(\alpha,\beta)}(x)]^T. \tag{8}$$

Some other properties of the Jacobi polynomials are presented as follows:

$$(1) P_i^{(\alpha,\beta)}(0) = (-1)^i \frac{\Gamma(i + \beta + 1)}{\Gamma(i + \alpha + \beta + 1)} \sum_{k=0}^i \frac{(-1)^k \Gamma(i + k + \alpha + \beta + 1)}{\Gamma(k + \beta + 1) k! (i - k)! 2^k},$$

$$(2) \frac{d^i}{dx^i} P_n^{(\alpha,\beta)}(x) = \frac{\Gamma(n + \alpha + \beta + i + 1)}{2^i \Gamma(n + \alpha + \beta + 1)} P_{n-i}^{(\alpha+i, \beta+i)}(x).$$

**Lemma 1.**

The Jacobi polynomial  $P_i^{(\alpha,\beta)}(x)$  can be obtained in the form of:

$$P_i^{(\alpha,\beta)}(x) = \sum_{k=0}^i \gamma_k^{(i)} x^k,$$

where  $\gamma_k^{(i)}$  are

$$\begin{aligned} \gamma_k^{(i)} &= (-1)^{i-k} \binom{i + k + \alpha + \beta}{k} \frac{\Gamma(i + \beta + 1)}{2^k \Gamma(i + k + \alpha + \beta + 1)} \\ &\times \sum_{l=0}^{i-k} \frac{(-1)^l \Gamma(i + k + l + \alpha + \beta + 1)}{2^l \Gamma(l + k + \beta + 1) l! (i - k - l)!}. \end{aligned}$$

**Proof:**

The coefficients  $\gamma_k^{(i)}$  can be obtained as:

$$\gamma_k^{(i)} = \frac{1}{k!} \frac{d^k}{dx^k} P_i^{(\alpha,\beta)}(x) \Big|_{x=0}.$$

Now, by using properties (1) and (2) the lemma can be proved.  $\square$

**Lemma 2.**

If  $P_j^{(\alpha,\beta)}(x)$  and  $P_k^{(\alpha,\beta)}(x)$  are  $j$ -th and  $k$ -th shifted Jacobi polynomials, respectively, then the product of  $P_j^{(\alpha,\beta)}(x)$  and  $P_k^{(\alpha,\beta)}(x)$  can be written as

$$Q_{j+k}^{(\alpha,\beta)}(x) = \sum_{r=0}^{j+k} \lambda_r^{(j,k)} x^r. \quad (9)$$

**Proof:**

Defining the  $Q_{j+k}^{(\alpha,\beta)}(x) = P_j^{(\alpha,\beta)}(x) P_k^{(\alpha,\beta)}(x)$ , as a polynomial of degree  $j+k$ , leads to:

$$\begin{aligned} Q_{j+k}^{(\alpha,\beta)}(x) &= \left( \sum_{m=0}^j \gamma_m^{(j)} x^m \right) \left( \sum_{n=0}^k \gamma_n^{(k)} x^n \right) \\ &= \sum_{r=0}^{j+k} \lambda_r^{(j,k)} x^r. \end{aligned}$$

The relation between coefficients  $\lambda_n^{(j,k)}$  with coefficients  $\gamma_m^{(j)}$  and  $\gamma_m^{(k)}$  will be as follows:

**If  $j \geq k$  :**

$$r = 0, 1, \dots, j+k,$$

if  $r > j$  then

$$\lambda_r^{(j,k)} = \sum_{l=r-j}^k \gamma_{r-l}^{(j)} \gamma_l^{(k)},$$

else

$$r_1 = \min\{r, k\},$$

$$\lambda_r^{(j,k)} = \sum_{l=0}^{r_1} \gamma_{r-l}^{(j)} \gamma_l^{(k)},$$

end.

**If  $j < k$  :**

$$r = 0, 1, \dots, j+k,$$

if  $r \leq j$  then

$$r_1 = \min\{r, j\},$$

$$\lambda_r^{(j,k)} = \sum_{l=0}^{r_1} \gamma_{r-l}^{(j)} \gamma_l^{(k)},$$

else

$$r_2 = \min\{r, k\},$$

$$\lambda_r^{(j,k)} = \sum_{l=r-j}^{r_2} \gamma_{r-l}^{(j)} \gamma_l^{(k)},$$

end.

where the coefficients  $\gamma_m^{(n)}$  are defined by Lemma 1. Thus, the coefficients  $\lambda_r^{(j,k)}$  is determined.

□

**Lemma 3.**

$Q_{j+k}^{(\alpha,\beta)}(x)$  can be expanded as follows:

$$Q_{j+k}^{(\alpha,\beta)}(x) = \sum_{l=0}^{j+k} \Lambda_l^{(j,k)} (x+1)^l, \quad (10)$$

where  $\Lambda_l^{(j,k)}$  are obtained from the following relations,

$$\begin{aligned} \Lambda_{j+k}^{(j,k)} &= \lambda_{j+k}^{(j,k)}, \\ \Lambda_l^{(j,k)} &= \lambda_l^{(j,k)} - \sum_{m=l+1}^{j+k} \binom{m}{l} \Lambda_m^{(j,k)}, \quad l = j+k-1, j+k-2, \dots, 1, 0, \end{aligned} \tag{11}$$

where  $\lambda_l^{(j,k)}$  have been introduced by Lemma 2.

**Proof:**

The  $(x+1)^l$  can be written as:

$$(x+1)^l = \sum_{m=0}^l \binom{l}{m} x^m.$$

The goal is to obtain the  $\Lambda_l^{(j,k)}$  in terms of the  $\lambda_l^{(j,k)}$ . To this end, we rewrite Equation (10) as follows:

$$Q_{j+k}^{(\alpha,\beta)}(x) = \sum_{l=0}^{j+k} \sum_{m=0}^l \Lambda_l^{(j,k)} \binom{l}{m} x^m. \tag{12}$$

The coefficient of  $x^r$  in Equation (12) will be as:

$$\sum_{m=r}^{j+k} \binom{m}{r} \Lambda_m^{(j,k)}. \tag{13}$$

By using Equation (13), we rewrite Equation (12) as follows:

$$Q_{j+k}^{(\alpha,\beta)}(x) = \sum_{l=0}^{j+k} \left\{ \sum_{m=l}^{j+k} \binom{m}{l} \Lambda_m^{(j,k)} \right\} x^l.$$

According to Lemma 2, we have

$$\lambda_l^{(j,k)} = \sum_{m=l}^{j+k} \binom{m}{l} \Lambda_m^{(j,k)}, \quad l = 0, 1, \dots, j+k. \tag{14}$$

Solving the upper triangular system (14) as backwards leads to determine the unknown coefficients,  $\Lambda_l^{(j,k)}$ . Consequently, the desired result is achieved and we can use the Equation (10) instead the Equation (9).  $\square$

**Lemma 4.**

If  $l \geq 0$ , then we have

$$\begin{aligned} \int_{-1}^1 (x+1)^l P_i^{(\alpha,\beta)}(x) w^{(\alpha,\beta)}(x) dx &= \sum_{k=0}^i \left\{ \frac{(-1)^{i-k} 2^{l+\alpha+\beta+1} \Gamma(i+\beta+1)}{\Gamma(k+\beta+1) \Gamma(i+\alpha+\beta+1)} \right. \\ &\quad \times \left. \frac{\Gamma(i+k+\alpha+\beta+1) \Gamma(l+k+\beta+1) \Gamma(\alpha+1)}{k! (i-k)! \Gamma(l+k+\alpha+\beta+2)} \right\}. \end{aligned}$$

**Proof:**

Using the Equation (5) and definition of weight function, we have

$$\begin{aligned}
\int_{-1}^1 (x+1)^l P_i^{(\alpha,\beta)}(x) w^{(\alpha,\beta)}(x) dx &= \sum_{k=0}^i \frac{(-1)^{i-k} \Gamma(i+\beta+1) \Gamma(i+k+\alpha+\beta+1)}{2^k \Gamma(k+\beta+1) \Gamma(i+\alpha+\beta+1) k! (i-k)!} \\
&\times \int_{-1}^1 (x+1)^{l+k+\beta} (1-x)^\alpha dx \\
&= \sum_{k=0}^i \frac{(-1)^{i-k} 2^{l+\alpha+\beta+1} \Gamma(i+\beta+1) \Gamma(i+k+\alpha+\beta+1)}{\Gamma(k+\beta+1) \Gamma(i+\alpha+\beta+1) k! (i-k)!} \\
&\times \int_0^1 t^{l+k+\beta} (1-t)^\alpha dt \\
&= \sum_{k=0}^i \frac{(-1)^{i-k} 2^{l+\alpha+\beta+1} \Gamma(i+\beta+1) \Gamma(i+k+\alpha+\beta+1)}{\Gamma(k+\beta+1) \Gamma(i+\alpha+\beta+1) k! (i-k)!} \\
&\times B(l+k+\beta+1, \alpha+1),
\end{aligned}$$

where  $B(s, t)$  is the Beta function and defined as:

$$B(s, t) = \int_0^1 v^{s-1} (1-v)^{t-1} dv = \frac{\Gamma(s) \Gamma(t)}{\Gamma(s+t)}. \quad \square$$

**Lemma 5.**

If  $P_i^{(\alpha,\beta)}(x)$ ,  $P_j^{(\alpha,\beta)}(x)$ , and  $P_k^{(\alpha,\beta)}(x)$  are  $i$ -th,  $j$ -th, and  $k$ -th shifted Jacobi polynomials, respectively, then the following relation is established,

$$\begin{aligned}
q_{ijk} &= \int_{-1}^1 P_i^{(\alpha,\beta)}(x) P_j^{(\alpha,\beta)}(x) P_k^{(\alpha,\beta)}(x) w^{(\alpha,\beta)}(x) dx \\
&= \sum_{l=0}^{j+k} \left\{ \sum_{m=0}^i \frac{(-1)^{i-m} \Lambda_l^{(j,k)} 2^{l+\alpha+\beta+1} \Gamma(l+m+\beta+1)}{\Gamma(m+\beta+1) \Gamma(i+\alpha+\beta+1)} \right. \\
&\quad \left. \times \frac{\Gamma(i+\beta+1) \Gamma(i+m+\alpha+\beta+1) \Gamma(\alpha+1)}{\Gamma(l+m+\alpha+\beta+2) (i-m)! m!} \right\},
\end{aligned}$$

where  $\Lambda_l^{(j,k)}$  were introduced in Lemma 3.

**Proof:**

Assume  $P_j^{(\alpha,\beta)}(x) P_k^{(\alpha,\beta)}(x) = Q_{j+k}^{(\alpha,\beta)}(x)$ . Using Equation (5), Lemmas 3 and 4 leads to:

$$\begin{aligned} \int_{-1}^1 P_i^{(\alpha,\beta)}(x) P_j^{(\alpha,\beta)}(x) P_k^{(\alpha,\beta)}(x) w^{(\alpha,\beta)}(x) dx &= \int_{-1}^1 P_i^{(\alpha,\beta)}(x) Q_{j+k}^{(\alpha,\beta)}(x) w^{(\alpha,\beta)}(x) dx \\ &= \sum_{l=0}^{j+k} \Lambda_l^{(j,k)} \int_{-1}^1 (x+1)^l P_i^{(\alpha,\beta)}(x) w^{(\alpha,\beta)}(x) dx \\ &= \sum_{l=0}^{j+k} \left\{ \sum_{m=0}^i \frac{(-1)^{i-m} \Lambda_l^{(j,k)} 2^{l+\alpha+\beta+1} \Gamma(l+m+\beta+1)}{\Gamma(m+\beta+1) \Gamma(i+\alpha+\beta+1)} \right. \\ &\quad \left. \times \frac{\Gamma(i+\beta+1) \Gamma(i+m+\alpha+\beta+1) \Gamma(\alpha+1)}{\Gamma(l+m+\alpha+\beta+2) (i-m)! m!} \right\}. \end{aligned}$$

Thus, desirable result is obtained.  $\square$

In performing arithmetic and other operations on the Jacobi bases, we frequently encounter the integration of the vector  $\Phi(x)$  defined by Equation (8) which is called the operational matrix of the integration. Hence, the matrix relations must be obtained. In this section, this operational matrix will be derived. To this end, some useful lemmas and theorems are stated.

**Theorem 6.**

Let  $\Phi(x)$  be the Jacobi vector in Equation (8). Then,

$$\int_0^x \Phi(t) dt \simeq M \Phi(x),$$

where  $M$  is the  $(N+1) \times (N+1)$  operational matrix of the integration and is defined by:

$$M = \begin{bmatrix} \Omega(0,0) & \Omega(0,1) & \dots & \Omega(0,N) \\ \Omega(1,0) & \Omega(1,1) & \dots & \Omega(1,N) \\ \vdots & \vdots & \ddots & \vdots \\ \Omega(N,0) & \Omega(N,1) & \dots & \Omega(N,N) \end{bmatrix},$$

where

$$\Omega(i,0) = \omega_{i0k} + \theta_i, \quad i = 0, 1, \dots, N, \quad k = 0, 1, \dots, i, \tag{15}$$

$$\Omega(i,j) = \sum_{k=0}^i \omega_{ijk}, \quad i = 0, 1, \dots, N, \quad j = 1, 2, \dots, N, \tag{16}$$

and  $\theta_i$  and  $\omega_{ijk}$  are given by

$$\begin{aligned} \theta_i &= \frac{(-1)^{i-k} \Gamma(i+\beta+1) \Gamma(i+k+\alpha+\beta+1)}{\Gamma(k+\beta+1) \Gamma(i+\alpha+\beta+1) (k+1)! (i-k)! 2^k}, \\ \omega_{ijk} &= \frac{(-1)^{i-k} 2^{\alpha+\beta+2} \Gamma(j+\beta+1) \Gamma(i+\beta+1) \Gamma(i+k+\alpha+\beta+1) \Gamma(\alpha+1)}{h_j \Gamma(k+\beta+1) \Gamma(j+\alpha+\beta+1) \Gamma(i+\alpha+\beta+1) (k+1)! (i-k)!} \\ &\quad \times \sum_{l=0}^j \frac{(-1)^{j-l} \Gamma(j+l+\alpha+\beta+1) \Gamma(l+k+\beta+2)}{\Gamma(l+\beta+1) \Gamma(l+k+\alpha+\beta+3) l! (j-l)!}, \\ &\quad i, j = 0, 1, \dots, N, \quad k = 0, 1, \dots, i. \end{aligned}$$



**Proof:**

Integration of the analytical form of  $P_i^{(\alpha,\beta)}(x)$ , i.e. Equation (5), from 0 to  $x$  leads to:

$$\int_0^x P_i^{(\alpha,\beta)}(t) dt = \sum_{k=0}^i \frac{(-1)^{i-k} \Gamma(i+\beta+1) \Gamma(i+k+\alpha+\beta+1) (x+1)^{k+1}}{2^k \Gamma(k+\beta+1) \Gamma(i+\alpha+\beta+1) (k+1)! (i-k)!} \\ + \sum_{k=0}^i \frac{(-1)^{i-k} \Gamma(i+\beta+1) \Gamma(i+k+\alpha+\beta+1)}{2^k \Gamma(k+\beta+1) \Gamma(i+\alpha+\beta+1) (k+1)! (i-k)!}.$$

Now, one can approximate  $(x+1)^{k+1}$  in terms of shifted Jacobi polynomials as:

$$(x+1)^{k+1} = \sum_{j=0}^N a_{k,j} P_j^{(\alpha,\beta)}(x),$$

where

$$a_{k,j} = \frac{1}{h_j} \int_{-1}^1 (x+1)^{k+1} P_j^{(\alpha,\beta)}(x) w^{(\alpha,\beta)}(x) dx.$$

But according to Lemma 4 one has,

$$\int_{-1}^1 (x+1)^{k+1} P_j^{(\alpha,\beta)}(x) w^{(\alpha,\beta)}(x) dx = \sum_{l=0}^j \left\{ \frac{(-1)^{(j-l)} 2^{k+\alpha+\beta+2} \Gamma(j+l+\alpha+\beta+1)}{\Gamma(l+\beta+1) \Gamma(j+\alpha+\beta+1)} \right. \\ \left. \times \frac{\Gamma(j+\beta+1) \Gamma(k+l+\beta+2) \Gamma(\alpha+1)}{\Gamma(k+l+\alpha+\beta+3) l! (j-l)!} \right\}.$$

Therefore, Equation (15) will be as follows:

$$\int_0^x P_i^{(\alpha,\beta)}(t) dt = \sum_{k=0}^i \frac{(-1)^{i-k} \Gamma(i+\beta+1) \Gamma(i+k+\alpha+\beta+1)}{2^k \Gamma(k+\beta+1) \Gamma(i+\alpha+\beta+1) (k+1)! (i-k)!} \\ + \sum_{j=0}^N \left\{ \sum_{k=0}^i \frac{(-1)^{i-k} 2^{\alpha+\beta+2} \Gamma(i+k+\alpha+\beta+1) \Gamma(j+\beta+1) \Gamma(i+\beta+1) \Gamma(\alpha+1)}{h_j \Gamma(k+\beta+1) \Gamma(j+\alpha+\beta+1) \Gamma(i+\alpha+\beta+1) (i-k)! (k+1)!} \right. \\ \left. \times \sum_{l=0}^j \frac{(-1)^{j-l} \Gamma(j+l+\alpha+\beta+1) \Gamma(l+k+\beta+2)}{\Gamma(l+\beta+1) \Gamma(l+k+\alpha+\beta+3) (j-l)! l!} \right\} P_j^{(\alpha,\beta)}(x) \\ = \sum_{j=0}^N \Omega(i,j) P_j^{(\alpha,\beta)}(x),$$

where  $\Omega(i,j)$  have been given in Equations (15) and (16). Accordingly, rewriting the last relation as a vector form gives

$$\int_0^x P_i^{(\alpha,\beta)}(t) dt = [\Omega(i,0), \Omega(i,1), \dots, \Omega(i,N)] \Phi(x), \quad i = 0, 1, \dots, N.$$

This leads to the desired result.  $\square$

The following property of the product of two vectors  $\Phi(x)$  and  $\Phi^T(x)$  will also be used.

$$\Phi(x) \Phi^T(x) C \simeq \tilde{C} \Phi(x), \quad (17)$$

where  $C$  and  $\tilde{C}$  are a  $(N + 1) \times 1$  vector and a  $(N + 1) \times (N + 1)$  operational matrix of product, respectively.

**Theorem 7.**

The entries of the matrix  $\tilde{C}$ , in Equation (17), are computed as:

$$\tilde{C}_{jk} = \frac{1}{h_k} \sum_{i=0}^N C_i q_{ijk}, \quad j, k = 0, 1, \dots, N,$$

where  $q_{ijk}$  are computed by Lemma 5 and  $C_i$  are the entries of the vector  $C$  in Equation (17).

**Proof:**

The left side of equality (17) is as follows:

$$\Phi(x) \Phi^T(x) C = \begin{bmatrix} \sum_{i=0}^N C_i P_0^{(\alpha,\beta)}(x) P_i^{(\alpha,\beta)}(x) \\ \sum_{i=0}^N C_i P_1^{(\alpha,\beta)}(x) P_i^{(\alpha,\beta)}(x) \\ \vdots \\ \sum_{i=0}^N C_i P_N^{(\alpha,\beta)}(x) P_i^{(\alpha,\beta)}(x) \end{bmatrix}.$$

We put,

$$P_j^{(\alpha,\beta)}(x) P_i^{(\alpha,\beta)}(x) = \sum_{k=0}^N a_k P_k^{(\alpha,\beta)}(x), \quad i, j = 0, 1, \dots, N. \tag{18}$$

Multiplying both sides of Equation (18) by  $P_m^{(\alpha,\beta)}(x)$ ,  $m, n = 0, 1, \dots, N$ , and integration of the result from  $-1$  to  $1$  yields:

$$\begin{aligned} \int_{-1}^1 P_j^{(\alpha,\beta)}(x) P_i^{(\alpha,\beta)}(x) P_m^{(\alpha,\beta)}(x) w^{(\alpha,\beta)}(x) dx \\ = \sum_{k=0}^N a_k \int_{-1}^1 P_k^{(\alpha,\beta)}(x) P_m^{(\alpha,\beta)}(x) w^{(\alpha,\beta)}(x) dx \\ = a_m h_m, \quad m = 0, 1, \dots, N. \end{aligned}$$

Therefore,

$$a_m = \frac{1}{h_m} \int_{-1}^1 P_j^{(\alpha,\beta)}(x) P_i^{(\alpha,\beta)}(x) P_m^{(\alpha,\beta)}(x) w^{(\alpha,\beta)}(x) dx.$$

Now, suppose

$$\int_{-1}^1 P_j^{(\alpha,\beta)}(x) P_i^{(\alpha,\beta)}(x) P_m^{(\alpha,\beta)}(x) w^{(\alpha,\beta)}(x) dx = q_{ijm}.$$

We get

$$a_m = \frac{q_{ijm}}{h_m}, \quad i, j, m = 0, 1, \dots, N.$$

By substituting  $a_m$  into Equation (18) we have,

$$P_j^{(\alpha,\beta)}(x) P_i^{(\alpha,\beta)}(x) = \sum_{k=0}^N \frac{q_{ijk}}{h_k} P_k^{(\alpha,\beta)}(x), \quad i, j = 0, 1, \dots, N.$$

Therefore, each component of the vector  $\Phi(x) \Phi^T(x) C$  in Equation (18) is

$$\sum_{i=0}^N C_i P_j^{(\alpha,\beta)}(x) P_i^{(\alpha,\beta)}(x) = \sum_{k=0}^N \left\{ \frac{1}{h_k} \sum_{i=0}^N C_i q_{ijk} \right\} P_k^{(\alpha,\beta)}(x).$$

Thus, the desirable result is obtained.  $\square$

The next theorem presents the general formula to approximate the nonlinear terms, as  $v^r(x) u^s(x)$ , which may appear in nonlinear equations.

**Theorem 8.**

If  $c$  and  $v$  are the  $(N + 1) \times 1$  vectors,  $\tilde{c}$  and  $\tilde{v}$  are the  $(N + 1) \times (N + 1)$  operational matrices of the product such that,

$$u(x) \simeq \Phi^T(x) c = c^T \Phi(x), \quad v(x) \simeq \Phi^T(x) v = v^T \Phi(x), \quad \Phi(x) \Phi^T(x) c \simeq \tilde{c} \Phi(x),$$

and  $\Phi(x) \Phi^T(x) v \simeq \tilde{v} \Phi(x)$ , then the following proposition hold:

$$v^r(x) u^s(x) \simeq v^T (\tilde{v})^{r-1} \tilde{B}_{s-1} \Phi(x), \quad B_{s-1} = (\tilde{c}^T)^{s-1} c, \quad r, s = 1, 2, \dots .$$

**Proof:**

We have,

$$u^2(x) \simeq (\Phi^T(x) c)^2 = c^T \Phi(x) \Phi^T(x) c \simeq c^T \tilde{c} \Phi(x),$$

So, by use of induction,  $u^s(x)$  can be approximated as:

$$u^s(x) \simeq c^T (\tilde{c})^{s-1} \Phi(x), \quad s = 1, 2, \dots .$$

To similar way,  $v^r(x)$  is approximated as follows:

$$v^r(x) \simeq v^T (\tilde{v})^{r-1} \Phi(x), \quad r = 1, 2, \dots .$$

Using the expressed relations and induction is easily resulted,

$$v^r(x) u^s(x) \simeq v^T (\tilde{v})^{r-1} \tilde{B}_{s-1} \Phi(x), \quad B_{s-1} = (\tilde{c}^T)^{s-1} c, \quad r, s = 1, 2, \dots . \quad \square$$

### 3. Description of proposed scheme

Let us consider a general nonlinear wave equation in the form

$$P(u, u_t, u_x, u_{tt}, u_{xx}, \dots) = 0, \tag{19}$$

where  $u = u(x, t)$  is an unknown function,  $P$  is a polynomial in  $u(x, t)$  and its derivatives in which higher order derivatives and nonlinear terms are involved. To obtain approximate solutions, the following steps are followed:

**Step 1.**

We combine the real variables  $x$  and  $t$  by a compound variable  $\eta$ ,

$$u(x, t) = u(\eta), \quad \eta = K(x \pm Vt), \tag{20}$$

where  $K$  and  $V$  are arbitrary constants. The wave transformation (20) converts Equation (19) to a nonlinear ordinary differential equation (ODE) for  $u = u(\eta)$  as:

$$Q(u, u', u'', u''', \dots) = 0, \tag{21}$$

where  $Q$  is a polynomial of  $u$  and its derivatives with respect to  $\eta$ .

**Step 2.**

Suppose  $u^{(n)}(\eta)$  is the highest order derivative in Equation (21) which can be expressed as follows:

$$u^{(n)}(\eta) \simeq \sum_{i=0}^N C_i P_i^{(\alpha, \beta)}(\eta) = \Phi^T(\eta) C, \tag{22}$$

where  $P_i^{(\alpha, \beta)}(\eta)$  are the Jacobi polynomials of degree  $i$  and  $C_i$  are the unknown coefficients which should be determined. Then the other terms in Equation (21) can be approximated by integrating of Equation (22) from 0 to  $\eta$  as follows:

$$\begin{aligned} u^{(n-1)}(\eta) &\simeq \Phi^T(\eta) M^T C + u^{(n-1)}(0) \simeq \Phi^T(\eta) M^T C + \Phi^T(\eta) U_1, \\ u^{(n-2)}(\eta) &\simeq \Phi^T(\eta) (M^T)^2 C + \Phi^T(\eta) M^T U_1 + \Phi^T(\eta) U_2, \\ &\vdots \end{aligned} \tag{23}$$

$$u(\eta) \simeq \Phi^T(\eta) (M^T)^n C + \Phi^T(\eta) \left\{ \sum_{k=1}^n (M^T)^{n-k} U_k \right\},$$

where  $M$  is the integral operational matrix,  $u^{(r)}(0) \simeq \Phi^T(\eta) U_{n-r}$ ,  $r = 0, 1, \dots, n-1$ , and  $u^{(r)}(0)$  are obtained from the initial conditions of the principle problem. Substituting the approximations (23) into Equation (21) leads to the nonlinear algebraic equation. By using the roots of  $P_{N+1}^{(\alpha, \beta)}(\eta)$ , the algebraic equation resulted is collocated in  $N + 1$  nodes. Hereby, the algebraic equation reduces the problem to solve a system of nonlinear algebraic equations and unknown coefficients are obtained.

**Step 3.**

Because the approximate solution has a polynomial form it can not indicate the soliton nature of the exact solution; we define a rational exponential approximation (REA) as:

$$u_{REA}(\eta) = \frac{\sum_{j=-e}^f a_j e^{j\eta}}{\sum_{k=-p}^q b_k e^{k\eta}}, \quad b_q = 1, \quad \eta = K(x \pm Vt), \tag{24}$$

where the numerator and denominator have no common factors and  $a_j$  and  $b_k$  are unknown coefficients which are determined by using the coefficients in the Taylor expansion of the

approximate solution obtained of the Step 2. For this reason, suppose  $\sum_{i=0}^{e+f+p+q+1} d_i^{(1)} \eta^i$  and  $\sum_{i=0}^{e+f+p+q+1} d_i^{(2)} \eta^i$  are the Taylor expansion of (24) and solution series in Step 2. Equating powers of  $\eta$  in two series leads to  $e + f + p + q + 1$  algebraic equations and completes the determination of the coefficients  $a_j$  and  $b_k$ .

#### 4. Applications of method

##### Example 1.

The nonlinear dispersive equation formulated by Korteweg and de Vries (KdV) in simplest form is given by Wazwaz (2009),

$$u_t - 6uu_x + u_{xxx} = 0. \quad (25)$$

This equation models a variety of nonlinear phenomena including ion acoustic waves in plasma and shallow water waves. The first three conservation laws for the KdV equation are as follows (Wazwaz (2009)),

$$I_1 = \int_a^b u(x, t) dx, \quad I_2 = \int_a^b u^2(x, t) dx, \quad I_3 = \int_a^b \left( u^3(x, t) - \frac{1}{2} u_x^2(x, t) \right) dx, \quad (26)$$

To seek the soliton solution of Equation (25), we make the transformation  $\eta = K(x - Vt)$ . Then Equation (25) is reduced to the following ordinary differential equation,

$$-KVu' - 6Kuu' + K^3u''' = 0, \quad (27)$$

where  $K$  and  $V$  are arbitrary constants and superscripts indicate the ordinary derivatives with respect to  $\eta$ . The exact solution obtained by Ebaid (2007) in the form,

$$u(\eta) = -\frac{2K^2}{e^{-\eta} + 2 + e^{\eta}}, \quad \eta = K(x - Vt). \quad (28)$$

We need three conditions for Equation (27) as:

$$u(0) = \frac{-K^2}{2}, \quad u'(0) = 0, \quad u''(0) = \frac{K^2}{4}, \quad (29)$$

which are obtained from Equation (28). The nonlinear Equation (27) with the initial conditions (29) is approximated using the Jacobi Collocation method introduced in Section 3. For this end, let us consider the following approximation,

$$u'''(\eta) \simeq \Phi^T(\eta) C. \quad (30)$$

Integration of Equation (30) with respect to  $\eta$  from 0 to  $\eta$ , one gets the following approximation for  $u''(\eta)$ ,

$$u''(\eta) \simeq \Phi^T(\eta) M^T C + u''(0) \simeq \Phi^T(\eta) M^T C + \Phi^T(\eta) U_1, \tag{31}$$

where  $u''(0)$  is approximated by  $\Phi^T(\eta) U_1$  which  $U_1$  is a  $(N + 1) \times 1$  known vector. Again, integrating Equation (31) with respect to  $\eta$  from 0 to  $\eta$ , one gets the following approximation for  $u'(\eta)$ ,

$$u'(\eta) \simeq \Phi^T(\eta) (M^T)^2 C + \Phi^T(\eta) M^T U_1 + \Phi^T(\eta) U_2, \tag{32}$$

where  $\Phi^T(\eta) U_2 \simeq u'(0)$ . Finally, integrating Equation (32) with respect to  $\eta$  leads to get the following approximation for  $u(\eta)$ ,

$$u(\eta) \simeq \Phi^T(\eta) (M^T)^3 C + \Phi^T(\eta) (M^T)^2 U_1 + \Phi^T(\eta) M^T U_2 + \Phi^T(\eta) U_3, \tag{33}$$

where  $\Phi^T(\eta) U_3 \simeq u(0)$ . Also, the nonlinear term in Equation (27) is approximated as follows:

$$u(\eta) u'(\eta) \simeq V_1^T \Phi(\eta) \Phi^T(\eta) V_2 \simeq V_1^T \tilde{V}_2 \Phi(\eta) = \Phi^T(\eta) \tilde{V}_2^T V_1, \tag{34}$$

where  $V_1 = (M^T)^3 C + (M^T)^2 U_1 + M^T U_2 + U_3$ ,  $V_2 = (M^T)^2 C + M^T U_1 + U_2$ , and  $\tilde{V}_2$  is operational matrix of product and its entries are determined in terms of the components of the vector  $V_2$ . Substituting the approximations (30)–(34) into Equation (27), leads to the following nonlinear algebraic equation.

$$\Phi^T(\eta) \left\{ -KV \left( (M^T)^2 C + M^T U_1 + U_2 \right) - 6K \tilde{V}_2^T V_1 + K^3 C \right\} \approx 0. \tag{35}$$

Setting  $K = 1$ ,  $V = K^2$ ,  $N = 20$ , and using the roots of  $P_{21}^{(\alpha,\beta)}(\eta)$ , Equation (35) is collocated in 21 collocation nodes for different values of  $\alpha$  and  $\beta$  parameters. Hereby, Equation (35) reduces the problem to solve a system of nonlinear algebraic equations and unknown coefficients are obtained for some values of  $\alpha$  and  $\beta$  parameters. Substituting the resultant vector  $C$  into Equation (33) leads to an approximate solution to the exact solution (28). Now, in order to improve the approximate solution (28) and achieve the soliton solutions, four cases are considered for the rational approximation (24):

**Case I**

$$e = f = 1, p = q = 1,$$

In this case, Equation (24) will be as follows:

$$u_{ERA}(\eta) = \frac{a_{-1}e^{-\eta} + a_0 + a_1e^{\eta}}{b_{-1}e^{-\eta} + b_0 + e^{\eta}}. \tag{36}$$

Equating the Taylor expansions of (36) and (33) yields a set of algebraic equations for  $a_{-1}$ ,  $a_0$ ,  $a_1$ ,  $b_{-1}$ , and  $b_0$ . Solving the system of algebraic equations with the aid of Maple, the coefficients are obtained. Table 1 shows the maximum absolute errors of the approximate solutions for different

values of  $\alpha$  and  $\beta$  parameters. Table 2 displays the numerical values of conservation quantities (26) in various times for  $\alpha = \beta = 1/2$ ,  $\alpha = 2$ ,  $\beta = 2$ ,  $a = -20$ , and  $b = 100$ . The analytical values are:  $I_1 = -2$ ,  $I_2 = 0.6666666666$ , and  $I_3 = -0.3333333333$ . As it can be seen from Table 2, the numerical values are almost equal the analytical values of conservation quantities. This shows the proposed scheme is stable. Also, the absolute errors functions obtained by the proposed method are displayed in Figure 1 for  $\alpha = 1$ ,  $\beta = 2$ , and  $t = 1, 15, 30$ .

**Table 1.** Maximum absolute errors of Example 1 for different values of  $\alpha$  and  $\beta$ ,  $e = f = 1$  and  $p = q = 1$

$(\alpha, \beta)$	$Error_{Abs}$	$(\alpha, \beta)$	$Error_{Abs}$
(0, 0)	$1.5 \times 10^{-10}$	(1, 2)	$2.5 \times 10^{-12}$
$(\frac{1}{2}, \frac{1}{2})$	$4.0 \times 10^{-12}$	(1, 1)	$3.0 \times 10^{-12}$
$(-\frac{1}{2}, \frac{1}{2})$	$6.0 \times 10^{-12}$	(2, 2)	$2.0 \times 10^{-12}$
$(\frac{1}{2}, -\frac{1}{2})$	$6.0 \times 10^{-12}$	(8, 7)	$2.0 \times 10^{-13}$
$(-\frac{1}{2}, 1)$	$5.0 \times 10^{-12}$	(10, 10)	$9.0 \times 10^{-14}$

**Table 2.** Numerical values of  $I_1$ ,  $I_2$ , and  $I_3$  of Example 1 for  $\alpha = \beta = \frac{1}{2}$ ,  $\alpha = \beta = 2$ , and  $e = f = p = q = 1$

		$(\alpha, \beta) = (2, 2)$	
$t$	$I_1$	$I_2$	$I_3$
0	-1.9999999956366	0.666666667464	-0.33333323040
5	-1.999999997311	0.666666672909	-0.3333331863
10	-1.999999997587	0.666666662266	-0.33333318910
15	-1.999999997589	0.666666672924	-0.3333331072
20	-1.999999997589	0.666666672061	-0.33333326198
25	-1.999999997589	0.666666665480	-0.33333347100
		$(\alpha, \beta) = (\frac{1}{2}, \frac{1}{2})$	
$t$	$I_1$	$I_2$	$I_3$
0	-1.999999995370	0.666666665155	-0.333333335579
5	-1.99999999464	0.6666666669404	-0.333333285760
10	-1.99999999492	0.666666665837	-0.33333329469
15	-1.99999999492	0.666666667028	-0.333333293896
20	-1.99999999492	0.666666667870	-0.333333313797
25	-1.99999999492	0.666666661850	-0.333333377706

**Case II**

$e = f = 2, p = q = 2,$

In this case, Equation (24) will be as follows:

$$u_{ERA}(\eta) = \frac{a_{-2} e^{-2\eta} + a_{-1} e^{-\eta} + a_0 + a_1 e^{\eta} + a_2 e^{2\eta}}{b_{-2} e^{-2\eta} + b_{-1} e^{-\eta} + b_0 + b_1 e^{\eta} + b_2 e^{2\eta}}. \tag{37}$$

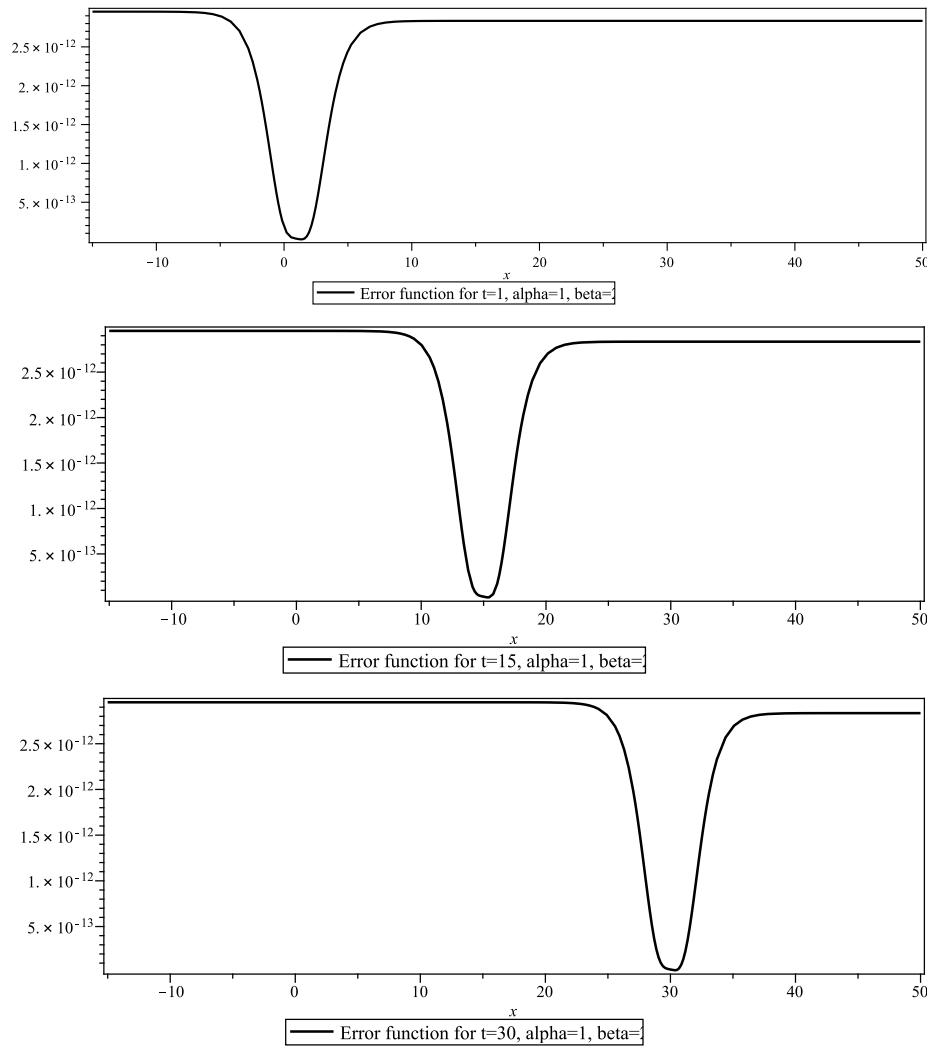

**Figure 1.** Behavior of error function of Example 1 for  $\alpha = 1, \beta = 2, t = 1, 15, 30$

Equating the Taylor expansions of (37) and (33) yields a set of algebraic equations for  $a_{-2}, a_{-1}, a_0, a_1, a_2, b_{-2}, b_{-1}, b_0,$  and  $b_1$ . Solving the system of algebraic equations the coefficients are obtained. Table 3 shows the maximum absolute errors of the approximate solutions for different values of  $\alpha$  and  $\beta$  parameters. Table 4 displays the numerical values of conservation quantities (26) in various times for  $\alpha = \beta = 1/2, \alpha = 2, \beta = 2, a = -20,$  and  $b = 100$ . As can be seen from Table 4, the numerical values are almost equal the analytical values of conservation quantities. This shows the proposed scheme is stable. Also, the approximate solution and absolute error function obtained by the proposed method are displayed in Figure 2 for  $\alpha = 8$  and  $\beta = 7$ .

**Case III**

$$e = f = 1, p = q = 2,$$

In this case, Equation (24) will be as follows:



$$u_{ERA}(\eta) = \frac{a_{-1} e^{-\eta} + a_0 + a_1 e^{\eta}}{b_{-2} e^{-2\eta} + b_{-1} e^{-\eta} + b_0 + b_1 e^{\eta} + e^{2\eta}}. \tag{38}$$

Equating the Taylor expansions of (38) and (33) yields a set of algebraic equations for  $a_{-1}$ ,  $a_0$ ,  $a_1$ ,  $b_{-2}$ ,  $b_{-1}$ ,  $b_0$ , and  $b_1$ . Solving the system of algebraic equations with the aide of Maple, the coefficients are obtained. Table 5 shows the maximum absolute errors of the approximate solutions for different values of  $\alpha$  and  $\beta$ . Table 6 displays the numerical values of conservation quantities (26) in various times for  $\alpha = \beta = 1/2$ ,  $\alpha = 2, \beta = 2$ ,  $a = -20$ , and  $b = 100$ . As can be seen from Table 6, the numerical values are almost equal the analytical values of conservation quantities. This shows the proposed scheme is stable. Table 7 displays different values of the exact and approximate solutions in various points for  $\alpha = -1/2, \beta = 1$ ,  $\alpha = \beta = 10$ . As can be seen from Table 7 the results of the solutions obtained by the proposed scheme are almost the same as the results of the exact solutions.

**Table 3.** Maximum absolute errors of Example 1 for different values  $\alpha$  and  $\beta$ ,  $e = f = 2$ , and  $p = q = 2$

$(\alpha, \beta)$	$Error_{Abs}$	$(\alpha, \beta)$	$Error_{Abs}$
(0, 0)	$1.8 \times 10^{-10}$	(1, 2)	$2.0 \times 10^{-12}$
$(\frac{1}{2}, \frac{1}{2})$	$4.0 \times 10^{-12}$	(1, 1)	$3.0 \times 10^{-12}$
$(-\frac{1}{2}, \frac{1}{2})$	$6.0 \times 10^{-12}$	(2, 2)	$2.0 \times 10^{-12}$
$(\frac{1}{2}, -\frac{1}{2})$	$6.0 \times 10^{-12}$	(8, 7)	$2.0 \times 10^{-13}$
$(-\frac{1}{2}, 1)$	$5.0 \times 10^{-12}$	(10, 10)	$9.0 \times 10^{-14}$

**Table 4.** Numerical values of  $I_1$ ,  $I_2$ , and  $I_3$  of Example 1 for  $\alpha = \beta = \frac{1}{2}$ ,  $\alpha = \beta = 2$  and  $e = f = p = q = 2$

		$(\alpha, \beta) = (2, 2)$	
$t$	$I_1$	$I_2$	$I_3$
0	-1.999999995805	0.66666666666822547	-0.3333333333320121
5	-2.000000000201	0.66666666666822550	-0.3333333333320121
10	-2.000000000230	0.66666666666822548	-0.3333333333320122
15	-2.000000000230	0.66666666666822550	-0.3333333333320121
20	-2.000000000230	0.66666666666822548	-0.3333333333320122
25	-2.000000000230	0.66666666666822550	-0.3333333333320121
		$(\alpha, \beta) = (\frac{1}{2}, \frac{1}{2})$	
$t$	$I_1$	$I_2$	$I_3$
0	-1.99999999605	0.666666666666988152	-0.33333333333305633
5	-2.00000000044	0.666666666666988157	-0.33333333333305631
10	-2.00000000047	0.666666666666988153	-0.33333333333305634
15	-2.00000000048	0.666666666666988157	-0.33333333333305631
20	-2.00000000048	0.666666666666988153	-0.33333333333305634
25	-2.00000000048	0.666666666666988157	-0.33333333333305631

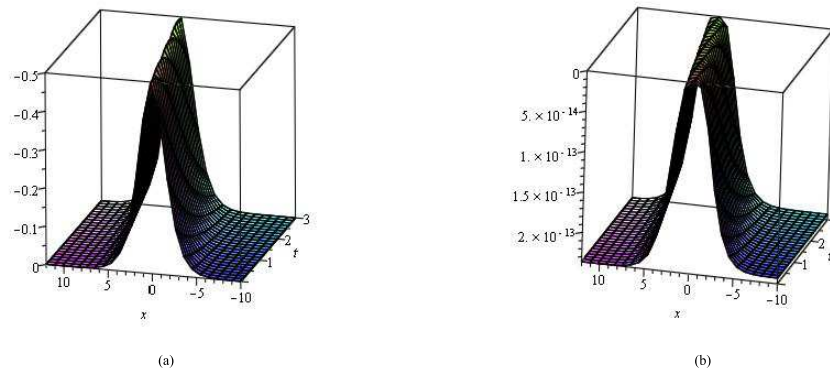

**Figure 2.** (a) Plot of approximate solution, (b) Plot of error function of Example 1 for  $\alpha = 8, \beta = 7, e = f = p = q = 2$

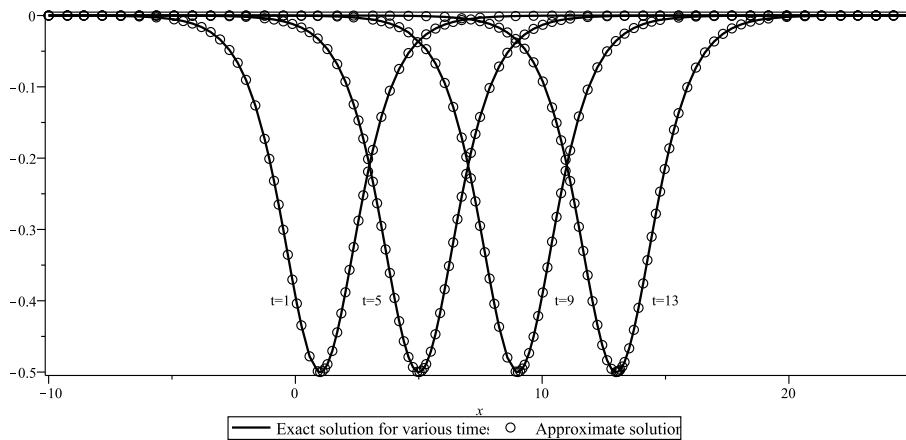

**Figure 3.** Plot of exact and approximate solutions of Example 1 for  $\alpha = \beta = 1/2$  and various times:  $t = 1, 5, 9, 13$

**Case IV**

$$e = 0, f = p = q = 2,$$

In this case, Equation (24) will be as follows:

$$u_{ERA}(\eta) = \frac{a_0 + a_1 e^\eta + a_2 e^{2\eta}}{b_{-2} e^{-2\eta} + b_{-1} e^{-\eta} + b_0 + b_1 e^\eta + e^{2\eta}}. \tag{39}$$

Equating the Taylor expansions of (39) and (33) yields a set of algebraic equations for  $a_{-1}, a_0, a_1, b_{-2}, b_{-1}, b_0,$  and  $b_1$ . Solving the system of algebraic equations, the coefficients are obtained. Table 8 shows the maximum absolute errors of the approximate solutions for different values of  $\alpha$  and  $\beta$  parameters. Table 9 displays the numerical values of conservation quantities (26) in various times for  $\alpha = \beta = 1, \alpha = -1/2, \beta = 1/2, a = -20,$  and  $b = 100$ . As can be seen from Table 9, the numerical values are almost equal the analytical values of conservation quantities. This shows the proposed scheme is stable. In Figure 3 the exact and approximate solutions are

compared for the case  $\alpha = \beta = 1/2$  and various times:  $t = 1, 5, 9, 13$ .

**Table 5.** Maximum absolute errors of Example 1 for different values  $\beta$ ,  $e = f = 1$  and  $p = q = 2$

$(\alpha, \beta)$	Error <sub>Abs</sub>	$(\alpha, \beta)$	Error <sub>Abs</sub>
(0, 0)	$3.0 \times 10^{-13}$	(1, 2)	$6.0 \times 10^{-15}$
$(\frac{1}{2}, \frac{1}{2})$	$1.0 \times 10^{-14}$	(1, 1)	$8.0 \times 10^{-15}$
$(-\frac{1}{2}, \frac{1}{2})$	$1.6 \times 10^{-14}$	(2, 2)	$4.0 \times 10^{-15}$
$(\frac{1}{2}, -\frac{1}{2})$	$1.6 \times 10^{-14}$	(8, 7)	$3.0 \times 10^{-16}$
$(-\frac{1}{2}, 1)$	$1.4 \times 10^{-14}$	(10, 10)	$1.2 \times 10^{-16}$

**Table 6.** Numerical values of  $I_1, I_2$ , and  $I_3$  of Example 1 for  $\alpha = \beta = \frac{1}{2}$ ,  $\alpha = \beta = 2$ , and  $e = f = 1, p = q = 2$

	$(\alpha, \beta) = (2, 2)$		
$t$	$I_1$	$I_2$	$I_3$
0	-1.9999999999997449	0.666666666666665677	-0.333333333333330047
5	-1.9999999999997450	0.666666666666665678	-0.333333333333330044
10	-1.9999999999997448	0.666666666666665678	-0.333333333333330047
15	-1.9999999999997315	0.666666666666665678	-0.333333333333330044
20	-1.99999999999977361	0.666666666666665678	-0.333333333333330047
25	-1.99999999997016208	0.666666666666665678	-0.333333333333330044
	$(\alpha, \beta) = (\frac{1}{2}, \frac{1}{2})$		
$t$	$I_1$	$I_2$	$I_3$
0	-1.9999999999994007	0.66666666666666435	-0.333333333333325685
5	-1.9999999999994009	0.66666666666666435	-0.333333333333325681
10	-1.9999999999994006	0.66666666666666435	-0.333333333333325685
15	-1.9999999999993874	0.66666666666666435	-0.333333333333325681
20	-1.99999999999973919	0.66666666666666435	-0.333333333333325685
25	-1.99999999997012767	0.66666666666666435	-0.333333333333325681

**Table 7.** Comparison of exact and approximate solutions of Example 1 for  $N = 20, \alpha = -\frac{1}{2}, \beta = 1$ , and  $\alpha = \beta = 10$

$(x_i, t_i)$	$u_{Exact}$	$u_{REA}(x, t)$ $(\alpha, \beta) = (-\frac{1}{2}, 1)$	$Error_{Abs}$	$u_{REA}(x, t)$ $(\alpha, \beta) = (10, 10)$	$Error_{Abs}$
(-3, 0.2)	-0.07526353790914	-0.07526353790913	$7.6405 \times 10^{-15}$	-0.07526353790914	$6.9076 \times 10^{-17}$
(-2.5, 0.4)	-0.09886713787329	-0.09886713787328	$9.4728 \times 10^{-15}$	-0.09886713787329	$8.5609 \times 10^{-17}$
(-2, 0.6)	-0.12871659835155	-0.12871659835155	$1.1405 \times 10^{-14}$	-0.12871659835155	$1.0302 \times 10^{-16}$
(-1.5, 1)	-0.14020743309021	-0.14020743309020	$1.2032 \times 10^{-14}$	-0.14020743309022	$1.0868 \times 10^{-16}$
(-1, 1.2)	-0.17960065808014	-0.17960065808012	$1.3700 \times 10^{-14}$	-0.17960065808014	$1.2365 \times 10^{-16}$
(3, 2)	-0.39322386648296	-0.39322386648296	$8.1597 \times 10^{-15}$	-0.39322386648296	$8.6290 \times 10^{-17}$
(5, 10)	-0.01329611334158	-0.01329611334158	$1.5486 \times 10^{-15}$	-0.01329611334158	$1.4014 \times 10^{-17}$
(10, 6)	-0.03532541242658	-0.03532541242657	$3.6503 \times 10^{-15}$	-0.03532541242658	$3.5526 \times 10^{-17}$

**Table 8.** Maximum absolute errors of Example 1 for different values  $\alpha$  and  $\beta$ ,  $e = 0$ , and  $f = p = q = 2$

$(\alpha, \beta)$	Error <sub>Abs</sub>	$(\alpha, \beta)$	Error <sub>Abs</sub>
(0, 0)	$5.0 \times 10^{-10}$	(1, 2)	$3.0 \times 10^{-12}$
$(\frac{1}{2}, \frac{1}{2})$	$9.0 \times 10^{-12}$	(1, 1)	$1.8 \times 10^{-11}$
$(-\frac{1}{2}, \frac{1}{2})$	$6.0 \times 10^{-12}$	(2, 2)	$2.0 \times 10^{-11}$
$(\frac{1}{2}, -\frac{1}{2})$	$6.0 \times 10^{-12}$	(8, 7)	$2.0 \times 10^{-13}$
$(-\frac{1}{2}, 1)$	$6.0 \times 10^{-12}$	(10, 10)	$3.0 \times 10^{-13}$

**Table 9.** Numerical values of  $I_1, I_2$  and  $I_3$  of Example 1 for  $\alpha = \beta = 1, \alpha = -\beta = -1/2$  and  $e = 0, f = p = q = 2$

		$(\alpha, \beta) = (1, 1)$	
$t$	$I_1$	$I_2$	$I_3$
0	-1.99999999975	0.66666666666597	-0.333418
5	-1.99999999977	0.66666666666618	-0.333376
10	-1.99999999978	0.66666666666597	-0.333418
15	-1.99999999980	0.66666666666618	-0.333376
20	-1.99999999982	0.66666666666597	-0.333418
25	-1.99999999981	0.66666666666618	-0.333376
		$(\alpha, \beta) = (-\frac{1}{2}, \frac{1}{2})$	
$t$	$I_1$	$I_2$	$I_3$
0	-1.99999999954	0.66666666666144339	-0.333333333333714859
5	-1.99999999957	0.66666666666144339	-0.333333333333714855
10	-1.99999999960	0.66666666666144339	-0.333333333333714859
15	-1.99999999963	0.66666666666144339	-0.333333333333714855
20	-1.99999999967	0.66666666666144339	-0.333333333333714859
25	-1.99999999967	0.66666666666144339	-0.333333333333714855

**Example 2.**

A well known model of nonlinear dispersive waves was proposed by Boussinesq in the form of Wazwaz (2009):

$$u_{tt} = u_{xx} + 3(u^2)_{xx} + u_{xxxx}. \tag{40}$$

The Boussinesq equation describes motion of long waves in shallow water under gravity and in a one-dimensional nonlinear lattice. The first four conservation laws for the Boussinesq equation are as follows (Wazwaz (2009)),

$$I_1 = \int_a^b u_t dx = 0, \quad I_2 = \int_a^b xu_t dx, \quad I_3 = \int_a^b (-u + tu_t) dx, \quad I_4 = \int_a^b (-xu + xtu_t) dx = 0, \tag{41}$$

To seek the soliton solution of Equation (40), we introduced the wave variable  $\eta = Kx + Vt$ . Then, Equation (40) is reduced to the following ordinary differential equation,

$$(V^2 - K^2)u'' - 6K^2(u')^2 - 6K^2uu'' - K^4u^{(4)} = 0, \tag{42}$$

where  $K$  and  $V$  are arbitrary constants and superscripts indicate the ordinary derivatives with respect to  $\eta$ . The exact solution obtained by Ebaid (2007) in the form,

$$u(\eta) = \frac{2K^2 e^{2\eta}}{e^\eta + 2 e^{2\eta} + e^{3\eta}}, \quad \eta = Kx + Vt. \quad (43)$$

We need four conditions for Equation (42) as:

$$u(0) = \frac{K^2}{2}, \quad u'(0) = 0, \quad u''(0) = \frac{-K^2}{4}, \quad u'''(0) = 0, \quad (44)$$

which are obtained from Equation (43). The nonlinear Equation (42) with the initial conditions (44) is approximated using the Jacobi Collocation method introduced in Section 3. For this end, let us consider the following approximations,

$$\begin{aligned} u^{(4)}(\eta) &\simeq \Phi^T(\eta) C, \\ u'''(\eta) &\simeq \Phi^T(\eta) M^T C + \Phi^T(\eta) U_1, \\ u''(\eta) &\simeq \Phi^T(\eta) (M^T)^2 C + \Phi^T(\eta) M^T U_1 + \Phi^T(\eta) U_2, \\ u'(\eta) &\simeq \Phi^T(\eta) (M^T)^3 C + \Phi^T(\eta) (M^T)^2 U_1 + \Phi^T(\eta) M^T U_2 + \Phi^T(\eta) U_3, \\ u(\eta) &\simeq \Phi^T(\eta) (M^T)^4 C + \Phi^T(\eta) (M^T)^3 U_1 + \Phi^T(\eta) (M^T)^2 U_2 + \Phi^T(\eta) M^T U_3 + \Phi^T(\eta) U_4, \end{aligned} \quad (45)$$

where  $u^{(k)}(0)$  are approximated by  $\Phi^T(\eta) U_{4-k}$ ,  $k = 0, 1, 2, 3, 4$ , which  $U_k$  are a  $(N + 1) \times 1$  known vectors. Also, the nonlinear terms in Equation (42) are approximated as follows:

$$\begin{aligned} (u')^2(\eta) &\simeq \Phi^T(\eta) \tilde{V}_1^T V_1, \\ u(\eta) u''(\eta) &\simeq \Phi^T(\eta) \tilde{V}_3^T V_2, \end{aligned} \quad (46)$$

where

$$\begin{aligned} V_1 &= (M^T)^3 C + (M^T)^2 U_1 + M^T U_2 + U_3, \\ V_2 &= (M^T)^4 C + (M^T)^3 U_1 + (M^T)^2 U_2 + M^T U_3 + U_4, \\ V_3 &= (M^T)^2 C + M^T U_1 + U_2, \end{aligned}$$

and  $\tilde{V}_1$  and  $\tilde{V}_3$  are operational matrices of product and their entries are determined in terms of the components of the vectors  $V_1$  and  $V_3$ , respectively. Substituting the approximations (45)–(46) into Equation (42), leads to the following nonlinear algebraic equation.

$$\Phi^T(\eta) \left\{ (V^2 - K^2) \left( (M^T)^2 C + M^T U_1 + U_2 \right) - 6K^2 \tilde{V}_1^T V_1 - 6K^2 \tilde{V}_3^T V_2 - K^4 C \right\} \approx 0. \quad (47)$$

Setting  $K = 1$ ,  $V = -K\sqrt{1 + K^2}$ ,  $N = 20$ , and using the roots of  $P_{21}^{(\alpha, \beta)}(\eta)$ , Equation (47) is collocated in 21 collocation nodes for different values of parameters  $\alpha$  and  $\beta$ . Hereby, the Equation (47) reduces the main problem to solve a system of nonlinear algebraic equations and unknown coefficients are obtained for some values of  $\alpha$  and  $\beta$  parameters. Substituting the vector  $C$  resulted into approximations (45) leads to an approximate solution for the exact solution (43). Now, in order to improve the approximate solution (45) and achieve the soliton solutions, two cases are considered for the rational approximation (24):

**Case I**

$$e = f = 1, p = q = 1,$$

In this case, equating the Taylor expansions of (36) and (45) yields a set of algebraic equations for  $a_{-1}, a_0, a_1, b_{-1},$  and  $b_0$ . Solving the system of algebraic equations with the aide of Maple, the coefficients are obtained. Table 10 shows the maximum absolute errors of the approximate solutions for different values of  $\alpha$  and  $\beta$  parameters. Table 11 displays the numerical values of conservation quantities (41) in various times for  $\alpha = \beta = 0, a = -50,$  and  $b = 50$ . As it can be seen from Table 11, the numerical values are almost equal the analytical values of conservation quantities. This shows the proposed scheme is stable. Also, the plots of approximate solution and absolute error function are displayed in Figure 4 for  $\alpha = \beta = 0$ .

**Table 10.** Maximum absolute errors of Example 2 for different values  $\alpha$  and  $\beta, e = f = 1$  and  $p = q = 1$

$(\alpha, \beta)$	Error <sub>Abs</sub>	$(\alpha, \beta)$	Error <sub>Abs</sub>
(0, 0)	$1.5 \times 10^{-10}$	(1, 1)	$3.0 \times 10^{-12}$
$(\frac{1}{2}, \frac{1}{2})$	$4.0 \times 10^{-12}$	(3, 3)	$1.2 \times 10^{-12}$
$(-\frac{1}{2}, \frac{1}{2})$	$6.0 \times 10^{-12}$	(5, 7)	$4.0 \times 10^{-13}$
$(\frac{1}{2}, -\frac{1}{2})$	$6.0 \times 10^{-12}$	(12, 10)	$8.0 \times 10^{-14}$

**Table 11.** Numerical values of  $I_1, I_2, I_3,$  and  $I_4$  of Example 2 for  $\alpha = \beta = 0, e = f = 1, p = q = 1$

$t$	$I_1$	$I_2$	$I_3$	$I_4$
0	-0.0000	2.828427125942	-1.999999985	$7.5659 \times 10^{-13}$
5	$-1.5616 \times 10^{-19}$	2.828427125942	-1.999999985	$1.0010 \times 10^{-12}$
10	$-4.4699 \times 10^{-17}$	2.828427125942	-1.999999985	$1.1782 \times 10^{-12}$
15	$-1.2795 \times 10^{-14}$	2.828427125941	-1.999999985	$7.6976 \times 10^{-12}$
20	$-3.6625 \times 10^{-12}$	2.828427125755	-1.999999985	$2.8534 \times 10^{-9}$
25	$-1.0484 \times 10^{-9}$	2.828427072474	-2.000000005	$1.0315 \times 10^{-6}$

**Case II**

$$e = f = 1, p = q = 2,$$

In this case, equating the Taylor expansions of (38) and (45) yields a set of algebraic equations for  $a_{-1}, a_0, a_1, b_{-2}, b_{-1}, b_0,$  and  $b_1$ . Solving the system of algebraic equations, the coefficients are obtained. Table 12 shows the maximum absolute errors of the approximate solutions for different values of  $\alpha$  and  $\beta$  parameters. Table 13 displays the numerical values of conservation quantities (41) in various times for  $\alpha = 5, \beta = 7, a = -50,$  and  $b = 50$ . As can be seen from Table 13, the numerical values are almost equal the analytical values of conservation quantities. This shows the proposed scheme is stable. In Figure 5 the exact and approximate solutions are compared for the case  $\alpha = \beta = 0$  and various times:  $t = 1, 5, 9, 13$ .

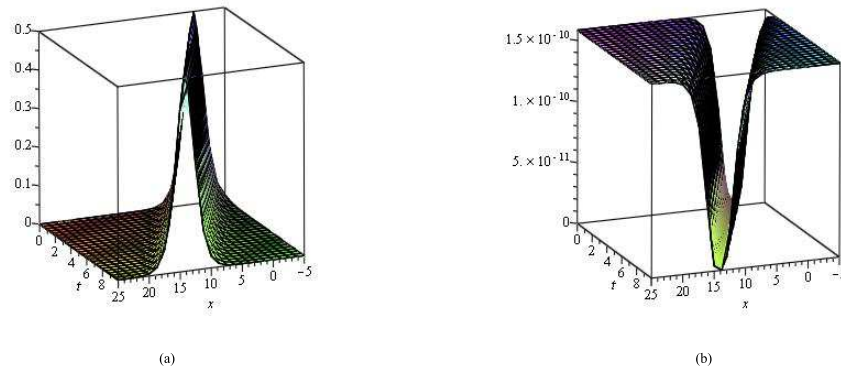

**Figure 4.** (a) Plot of approximate solution, (b) Plot of error function of Example 2 for  $\alpha = \beta = 0$ ,  $e = f = p = q = 1$

**Table 12.** Maximum absolute errors of Example 2 for different values  $\alpha$  and  $\beta$ ,  $e = f = 1$  and  $p = q = 2$

$(\alpha, \beta)$	$Error_{Abs}$	$(\alpha, \beta)$	$Error_{Abs}$
$(0, 0)$	$3.0 \times 10^{-13}$	$(1, 1)$	$8.0 \times 10^{-15}$
$(\frac{1}{2}, \frac{1}{2})$	$1.0 \times 10^{-14}$	$(3, 3)$	$2.5 \times 10^{-15}$
$(-\frac{1}{2}, \frac{1}{2})$	$1.6 \times 10^{-14}$	$(5, 7)$	$8.0 \times 10^{-16}$
$(\frac{1}{2}, -\frac{1}{2})$	$1.6 \times 10^{-14}$	$(12, 10)$	$1.0 \times 10^{-16}$

**Table 13.** Numerical values of  $I_1, I_2, I_3$  and  $I_4$  of Example 2 for  $\alpha = 5, \beta = 7$  and  $e = f = 1, p = q = 2$

$t$	$I_1$	$I_2$	$I_3$	$I_4$
0	$2.2673 \times 10^{-18}$	2.82842712475	-1.9999999999999958	$-4.0081 \times 10^{-16}$
5	$1.8568 \times 10^{-17}$	2.82842712475	-1.9999999999999959	$-6.4615 \times 10^{-16}$
10	$8.1641 \times 10^{-16}$	2.82842712475	-2.0000000000000033	$-3.8436 \times 10^{-13}$
15	$9.5569 \times 10^{-13}$	2.82842712470	-2.0000000000136556	$-6.9563 \times 10^{-10}$
20	$1.1253 \times 10^{-9}$	2.82842706744	-2.0000000217095266	$1.1056 \times 10^{-6}$
25	$1.3248 \times 10^{-9}$	2.82835965426	-2.0000321853046230	$1.6390 \times 10^{-3}$

**Example 3.**

The Kaup–Kuperschmidt equation fifth–order equation is given by (Wazwaz (2009)),

$$u_t + 20 uu_{xxx} + 50 u_x u_{xx} - 80 u^2 u_x - u_{xxxxx} = 0. \tag{48}$$

The first two conservation laws for the Kaup–Kuperschmidt equation are as follows, Wazwaz (2009),

$$I_1 = \int_a^b u \, dx, \quad I_2 = \int_a^b \left( \frac{1}{3} u^3 - \frac{1}{8} u_x^2 \right) \, dx. \tag{49}$$

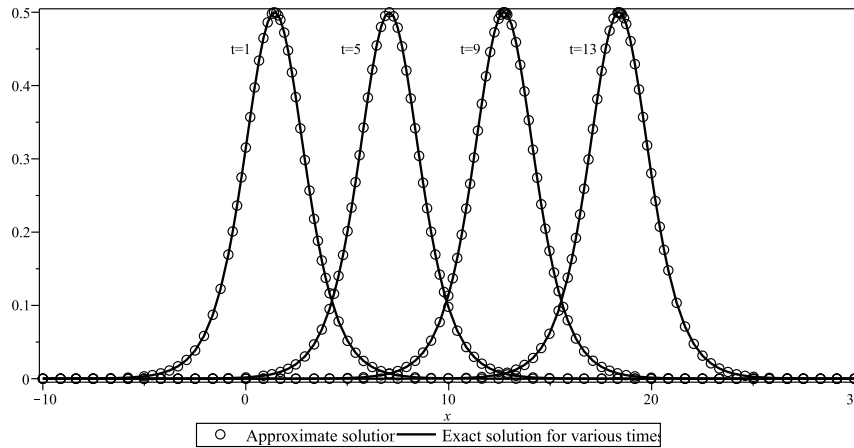

**Figure 5.** Plot of exact and approximate solutions of Example 2 for  $\alpha = \beta = 0$  and various times:  $t = 1, 5, 9, 13$

To seek the soliton solution of Equation (48), we introduced the wave variable  $\eta = x - Vt$ . Then Equation (48) reduce to the following ordinary differential equation,

$$-Vu' + 20 uu''' + 50 u'u'' - 80 u'u^2 - u^{(5)} = 0, \tag{50}$$

where  $V$  is arbitrary constant and superscripts indicate the ordinary derivatives with respect to  $\eta$ . The exact solution is obtained by Wazwaz (2009) in the form,

$$u(\eta) = \frac{1}{16} \frac{1 - 10 e^\eta + e^{2\eta}}{1 + 2 e^\eta + e^{2\eta}}, \quad \eta = x - Vt. \tag{51}$$

We need five conditions for Equation (50) as:

$$u(0) = -\frac{1}{8}, \quad u'(0) = 0, \quad u''(0) = \frac{3}{32}, \quad u'''(0) = 0, \quad u^{(4)}(0) = -\frac{3}{16}, \tag{52}$$

which are obtained from Equation (51). The nonlinear Equation (50) with the initial conditions Equation (52) is approximated by using the Jacobi Collocation method introduced in Section 3. For this end, let us consider the following approximations,

$$\begin{aligned} u^{(5)}(\eta) &\simeq \Phi^T(\eta) C, \\ u''''(\eta) &\simeq \Phi^T(\eta) M^T C + \Phi^T(\eta) U_1, \\ u''''(\eta) &\simeq \Phi^T(\eta) (M^T)^2 C + \Phi^T(\eta) M^T U_1 + \Phi^T(\eta) U_2, \\ u''(\eta) &\simeq \Phi^T(\eta) (M^T)^3 C + \Phi^T(\eta) (M^T)^2 U_1 + \Phi^T(\eta) M^T U_2 + \Phi^T(\eta) U_3, \\ u'(\eta) &\simeq \Phi^T(\eta) (M^T)^4 C + \Phi^T(\eta) (M^T)^3 U_1 + \Phi^T(\eta) (M^T)^2 U_2 + \Phi^T(\eta) M^T U_3 \\ &\quad + \Phi^T(\eta) U_4, \\ u(\eta) &\simeq \Phi^T(\eta) (M^T)^5 C + \Phi^T(\eta) (M^T)^4 U_1 + \Phi^T(\eta) (M^T)^3 U_2 + \Phi^T(\eta) (M^T)^2 U_3 \\ &\quad + \Phi^T(\eta) M^T U_4 + \Phi^T(\eta) U_5, \end{aligned} \tag{53}$$

where  $u^{(k)}(0)$  are approximated by  $\Phi^T(\eta) U_{5-k}$ ,  $k = 0, 1, \dots, 5$ , which  $U_k$  are a  $(N + 1) \times 1$  known vectors. Also, the nonlinear terms in Equation (42) are approximated as follows:

$$u(\eta)u''(\eta) \simeq \Phi^T(\eta) \tilde{V}_2^T V_1, \quad u'(\eta)u''(\eta) \simeq \Phi^T(\eta) \tilde{V}_4^T V_3, \quad u(\eta)u^2(\eta) \simeq \Phi^T(\eta) \tilde{W}^T V_3, \tag{54}$$



where

$$\begin{aligned} V_1 &= (M^T)^5 C + (M^T)^4 U_1 + (M^T)^3 U_2 + (M^T)^2 U_3 + M^T U_4 + U_5, \\ V_2 &= (M^T)^2 C + M^T U_1 + U_2, \\ V_3 &= (M^T)^4 C + (M^T)^3 U_1 + (M^T)^2 U_2 + M^T U_3 + U_4, \\ V_4 &= (M^T)^3 C + (M^T)^2 U_1 + M^T U_2 + U_3, \quad W = \tilde{V}_1^T V_1, \end{aligned}$$

and  $\tilde{V}_1, \tilde{V}_2, \tilde{V}_4$ , and  $\tilde{W}$  are operational matrices of product and their entries are determined in terms of the components of the vectors  $V_1, V_2, V_4$  and  $W$ , respectively. Substituting the approximations (53)–(54) into Equation (50), this leads to the following nonlinear algebraic equation.

$$\Phi^T(\eta) \left\{ -V \left( (M^T)^4 C + (M^T)^3 U_1 + (M^T)^2 U_2 + M^T U_3 + U_4 \right) + 20 \tilde{V}_2^T V_1 + 50 \tilde{V}_4^T V_3 - 80 C \right\} \approx 0. \tag{55}$$

Setting  $V = -1/16, N = 20$  and using the roots of  $P_{21}^{(\alpha,\beta)}(\eta)$ , Equation (55) is collocated in 21 collocation nodes for different values of parameters  $\alpha$  and  $\beta$ . Thus, Equation (55) reduces the problem to solve a system of nonlinear algebraic equations and unknown coefficients are obtained for some values of  $\alpha$  and  $\beta$  parameters. Substituting the vector  $C$  resulted into Equation (53) leads to an approximate solution for the exact solution (51). Now in order to improve the approximate solution (53) and achieve the soliton solutions and for simplicity we set  $e = f = p = q = 1$ . So, equating the Taylor expansions of (36) and (53) yields a set of algebraic equations for  $a_{-1}, a_0, a_1, b_{-1}$ , and  $b_0$ . Solving the system of algebraic equations with the aide of Maple, the coefficients are obtained. Table 14 shows the maximum absolute errors of the approximate solutions for different values of  $\alpha$  and  $\beta$ . Table 15 displays the numerical values of conservation quantities (49) in various times for  $\alpha = \beta = 0, \alpha = \beta = 1/2, \alpha = \beta = 10, a = -50$ , and  $b = 50$ . As can be seen from Table 15, the numerical values are almost equal the analytical values of conservation quantities. This shows the proposed scheme is stable.

**Table 14.** Maximum absolute errors of Example 3 for different values  $\alpha$  and  $\beta, e = f = p = q = 1$

$(\alpha, \beta)$	Error <sub>Abs</sub>	$(\alpha, \beta)$	Error <sub>Abs</sub>
(0, 0)	$1.8 \times 10^{-10}$	(1, 1)	$1.2 \times 10^{-12}$
$(\frac{1}{2}, \frac{1}{2})$	$1.6 \times 10^{-12}$	(4, 4)	$3.0 \times 10^{-13}$
$(-\frac{1}{2}, \frac{1}{2})$	$2.0 \times 10^{-12}$	(6, 8)	$1.2 \times 10^{-13}$
$(\frac{1}{2}, -\frac{1}{2})$	$2.0 \times 10^{-12}$	(10, 7)	$7.0 \times 10^{-14}$
$(1, \frac{1}{2})$	$1.4 \times 10^{-12}$	(10, 10)	$3.0 \times 10^{-14}$

**Table 15.** Numerical values of  $I_1$  and  $I_2$  of Example 3 for  $\alpha = \beta = 0, \alpha = \beta = 1/2, \alpha = \beta = 10$ , and  $e = f = p = q = 1$

$t$	$(\alpha, \beta) = (0, 0)$		$(\alpha, \beta) = (\frac{1}{2}, \frac{1}{2})$		$(\alpha, \beta) = (10, 10)$	
	$I_1$	$I_2$	$I_1$	$I_2$	$I_1$	$I_2$
0	5.50000970	0.0040364929	5.50000774	0.0040364861	5.500000257	0.00403623922
5	5.50000970	0.0040364929	5.50000774	0.0040364861	5.500000257	0.00403621428
10	5.50000970	0.0040364929	5.50000774	0.0040364861	5.500000257	0.00403621065
15	5.50000970	0.0040364929	5.50000774	0.0040364861	5.500000257	0.004036239218
20	5.50000970	0.0040364929	5.50000774	0.0040364861	5.500000257	0.004036235813
25	5.50000970	0.0040364929	5.50000774	0.0040364861	5.500000257	0.004036239218

## 5. Conclusion

In this paper, a computational method based on the Collocation method was presented for solving some of nonlinear partial differential equations in terms of one variable Jacobi polynomials by converting them to a nonlinear system of algebraic equations and then improving the approximate solutions obtained by introducing the rational exponential approximation. This study shows that the proposed method is efficient and practically well suited for use in finding approximate solutions for the KdV, Boussinesq, and Kaup–Kuperschmidt equations. The results indicate the proposed approach can be regarded as simple and applicable approach to numerically solve these type of nonlinear equations. It is predicted that the Jacobi collocation method will be a powerful tools for investigating approximate solutions and even analytic to wide classes of nonlinear wave equations. For numerical purposes the computer programs have been written in Maple 13.

## REFERENCES

- Achouri, T. and Omrani, K. (2009). Numerical solutions for the damped generalized regularized long-wave equation with a variable coefficient by Adomian decomposition method, *Commun. Nonlin. Numer. Sci. Simul.*, Vol. 14, pp. 2025–2033.
- Bhrawy, A. H. (2014). An efficient Jacobi pseudospectral approximation for nonlinear complex generalized Zakharov system, *Appl. Math. Comput.*, Vol. 247, pp. 30–46.
- Bhrawy, A. H., Doha, E. H., Baleanu, D. and Ezz–Eldien, S. S. (2014). A spectral tau algorithm based on Jacobi operational matrix for numerical solution of time fractional diffusion–wave equations, *J. Comput. Phys.*, doi:10.1016/j.jcp.2014.03.039.
- Bhrawy, A. H. and Zaky, M. A. (2015). A method based on the Jacobi tau approximation for solving multi–term time–space fractional partial differential equations, *J. Comput. Phys.*, Vol. 281, pp. 876–895.
- Bhrawy, A. H., Zaky, M. A. and Baleanu, D. (2015). New Numerical Approximations for Space–Time Fractional Burgers’ Equations via a Legendre Spectral–Collocation Method, *Rom. Rep. Phys.*, Vol. 67, No. 2, pp. 340–349.
- Dai, C. Q., Cen, X. and Wu, S. S. (2009). Exact travelling wave solutions of the discrete sine–Gordon equation obtained via the exp–function method, *Non. Anal.*, Vol. 70, pp. 58–63.
- Doha, E. H., Bhrawy, A. H., Abdelkawy, M. A. and Van Gorder, R. A. (2014). Jacobi–Gauss–Lobatto collocation method for the numerical solution of  $1+1$  nonlinear Schrödinger equations, *J. Comput. Phys.*, Vol. 261, pp. 244–255.
- Ebaid, A. (2007). Solitary wave solutions for some nonlinear evolution equations via Exp–function method, *Phys. Lett. A.*, Vol. 365, pp. 213–219.
- Ekici, M. (2017). Soliton and other solutions of nonlinear time fractional parabolic equations using extended  $G'/G$ –expansion method, *Optik–International Journal for Light and Electron Optics*, Vol. 130, pp. 1312–1319.
- Ekici, M., Mirzazadeh, M., Sonmezoglu, A., Zhou, Q., Triki, H., Zaka Ullah, M., Moshokoa, S.P. and Biswas, A. (2017). Optical solitons in birefringent fibers with Kerr nonlinearity by exp–function method, *Optik–International Journal for Light and Electron Optics*, Vol. 131,

- pp. 964-976.
- Kabir, M. M., Borhanifar, A. and Abazari, R. (2011). Application of  $(\frac{G'}{G})$ -expansion method to Regularized Long Wave (RLW) equation, *Com. Math. Appl.*, Vol. 61, pp. 2044–2047.
- Lu, J. (2011). An analytical approach to the Fornberg–Whitham type equations by using the variational iteration method, *Comput. Math. Appl.*, Vol. 61, pp. 2010–2013.
- Manafian, J., Fazli Aghdaei, M., Khalilian, M. and Sarbaz Jeddi, R. (2017). Application of the generalized  $G'/G$ -expansion method for nonlinear PDEs to obtaining soliton wave solution, *Optik–International Journal for Light and Electron Optics*, Vol. 135, pp. 395–406.
- Mohamed, M.S. and Gepreel, K.A. (2017). Reduced differential transform method for nonlinear integral member of Kadomtsev–Petviashvili hierarchy differential equations, *Journal of the Egyptian Mathematical Society*, Vol. 25, No. 1, pp. 1–7.
- Ravi, L.K., Saha Ray, S. and Sahoo, S. (2017). New exact solutions of coupled Boussinesq–Burgers equations by Exp–function method, *Journal of Ocean Engineering and Science*, Vol. 2, No. 1, pp. 34–46.
- Shehata, A. R. (2010). The traveling wave solutions of the perturbed nonlinear Schrodinger equation and the cubic–quintic Ginzburg Landau equation using the modified  $G'/G$ -expansion method, *Appl. Math. Comput.*, Vol. 217, pp. 1–10.
- Szegö, G. (1939). *Orthogonal Polynomials*, American Mathematical Society, Providence, RI.
- Wazwaz, A. M. (2007). Analytic study on the generalized fifth-order KdV equation: New solitons and periodic solutions, *Non. Sci. Num. Simul.* Vol. 12, pp. 1172–1180.
- Wazwaz, A. M. (2008a). New sets of solitary wave solutions to the KdV, mKdV, and the generalized KdV equations, *Non. Sci. Num. Simul.*, Vol. 13, pp. 331–339.
- Wazwaz, A. M. (2008b). New travelling wave solutions to the Boussinesq and the Klein–Gordon equations, *Non. Sci. Num. Simul.* Vol. 13, pp. 889–901.
- Wazwaz, A. M. (2008c). The Hirota’s bilinear method and the tanh–coth method for multiple–soliton solutions of the Sawada–Kotera–Kadomtsev–Petviashvili equation, *Appl. Math. Comput.*, Vol. 200, pp. 160–166.
- Wazwaz, A. M. (2008d). Solitary wave solutions of the generalized shallow water wave (GSWW) equation by Hirota’s method, tanh–coth method and Exp–function method, *Appl. Math. Comput.*, Vol. 202, pp. 275–286.
- Wazwaz, A.M. (2009). *Partial Differential Equations and Solitary Waves Theory*, Springer, Nonlinear Physical Science, Higher Education Press, Beijing.
- Wazwaz, A. M. (2010). A study on an integrable system of coupled KdV equations, *Non. Sci. Num. Simul.*, Vol. 15, pp. 2846–2850.
- Yang, X.J., Machado, J.A.T. and Srivastava, H.M. (2016). A new numerical technique for solving the local fractional diffusion equation: Two–dimensional extended differential transform approach, *Applied Mathematics and Computation*, Vol. 274, pp. 143–151.
- Yu, J., Jing, J., Sun, Y. and Wu, S. (2016).  $(n + 1)$ -Dimensional reduced differential transform method for solving partial differential equation, *Applied Mathematics and Computation*, Vol. 273, pp. 697–705.
- Zheng, H., Shunji, K., Fujun, N. and Anyuan, L. (2015). Three-dimensional frost heave evaluation based on practical Takashi’s equation, *Cold Regions Science and Technology*. Vol. 118, pp. 30–37.