

Physics 2121 Laboratory Manual



**Original Authors: Lon Turnbull
and David Wagoner
Revised by: Brian Cudnik, Midhat
Asghar, and Angela Ortíz**

Fall 2004

Table of Contents

The following is a list of experiments prepared for Physics 2121, General Physics Lab II. Of this list of fifteen, ten to twelve will be selected by your instructor to be performed this semester. Many of these labs involve use of computers, such as the Macs in 307 and the Dell PC's in 301. The computerized version of a particular lab, if available, follows the traditional version, giving the class a choice of whether to use the computerized equipment. Help for using the computers is located in a different manual.

Introduction (this document and the labs)	3
1. Simple Harmonic Motion: Simple Pendulum.....	9
2. Simple Harmonic Motion: Hook's Law	12
3. Standing (Transverse) Waves using Vibrating Strings.....	16
4. The Speed of Sound in Air	19
5. The Coefficient of Linear Expansion of Metals	22
6. Calorimetry: the Melting of Ice (Heats of Fusion / Vaporization of Water)	24
7. Boyle's Law / Finding the Absolute Zero (Gay Lussac's Law).....	27
8. Ohm's Law	20
9. Series and Parallel Circuits	32
10. Resistivity	36
11. Computer Experiment Simulation (Thermodynamics, E & M, Optics, or Modern).....	38
12. Index of Refraction of Laser Light	40
13. Concave and Convex Lenses	42
14. Laser with Diffraction Grating.....	45

Please note that several of these labs may be switched with exercises not included in this manual, i.e. "instructor's choice", which may occur for up to three lab periods.

Introduction (to this Document and the Labs)

Introduction

This laboratory manual has descriptions of some of the laboratories which you will be doing this term. It also explains some of the concepts required to be understood in order to successfully complete this course. This laboratory manual is required reading material for this course.

The student will be learning to apply the scientific method. Science is the study of the interrelationships of natural phenomena and of their origins. The scientific method is a paradigm that uses logic, common sense, and experience in the interpretation of observations. The underlying basis of the scientific method is understanding through repeatable experiments. No theory is held to be tenable unless the results it predicts are in accord with experimental results.

A major problem is: how does one quantify data so that experiments can adequately be compared? Physicists try to apply a rigorous method of error analysis, and then compare results with respect to the inherent experimental errors. If two experiments produce results that are the same to within experimental error, then we say that the experiments have validated each other.

Error analysis

It is up to your instructor whether some form of error analysis will be included in your lab assignments. It is recommended for the University Physics Laboratories, but not recommended for the General Physics Laboratories. In the event the instructor includes error analysis in the course work, a brief discussion on error propagation follows.

In physics we often do experiments where we wish to calculate a value that has a functional dependence on some measurable quantities, for example:

$$y = f(x, z)$$

or

$$y = f(x_1, x_2, \dots, x_n)$$

In some cases, we wish to determine how close our experimental value is compared to the published result. This is usually performed by finding the percent difference between the experimental value and the theoretical value. The percent difference is given by:

$$\%diff = \left| \frac{(\text{experimental} - \text{theoretical})}{\text{theoretical}} \right| \times 100\%$$

Errors in measurement can readily be obtained in the following ways:

1. If only one measurement was taken, use $\frac{1}{2}$ the smallest scale division of the measuring device.
2. If multiple measurements were taken:

- use standard deviation function on your calculator.
- or use the standard deviation formula:

$$\sigma_x = \sqrt{\frac{1}{n-1} \left(\sum_{i=1}^n (x_i - \bar{x})^2 \right)}$$

$$\bar{x} = \frac{\sum_{i=1}^n x_i}{n}$$

Experimental Errors

There are two kinds of errors:

- systematic: associated with particular measurement techniques
 - improper calibration of measuring instrument
 - human reaction time
 - is the “same” error each time. This means that the error can be corrected if the experimenter is clever enough to discover the error.
- random error: unknown and unpredictable variations
 - fluctuations in temperature or line voltage
 - mechanical vibrations of the experimental setup
 - unbiased estimates of measurement readings
 - is a “different” error each time. This means that the experimenter cannot correct the error after the data has been collected.

These errors can be made in two ways:

- Personal: from personal bias or carelessness in reading an instrument (e.g., parallax), in recording observations, or in mathematical calculations.
- External: from the natural limitations of the physical devices. Examples are: old and misused equipment, finite accuracy of measurement devices, heat flow, extraneous electric fields, vibrations, etc.

Accuracy: how close to the true value is the result?

Precision: how much spread is in the data?

- the more precise a group of measurements, the closer together they are
- high precision **does not** necessarily imply high accuracy

Significant Digits

- exact factors have no error (e.g., 10, π)
- all measured numbers have some error or uncertainty
 - this error must be calculated or estimated and recorded with every final expression in a laboratory report
 - the degree of error depends on the quality and fineness of the scale of the measuring device 3
- use all of the significant figures on a measuring device. For example, if a measuring device is accurate to 3 significant digits, use all of the digits in

your answer. If the measured value is 2.30 kg, then the zero is a significant digit and so should be recorded in your laboratory report notes.

- keep only a reasonable number of significant digits
 - e.g., $136.467 + 12.3 = 148.8$ units
 - e.g., 2.3456 ± 0.4345634523 units $\rightarrow 2.3 \pm 0.4$ units
 - NOTE: hand-held calculators give answers that generally have a false amount of precision.

Round these values correctly. As a rule, the final answer should have no more significant digits than the data from which it was derived.

Graphing Techniques

1. Graphs are either to be done on a computer (using either Excel or the graphing utility of DataStudio) or on quadrille-lined paper, for example, engineering paper.
2. We draw graphs for the following reasons:
 - to see the functional dependence, that is, does it look like a straight line, a curve, or random data
 - to average out the data
 - to fit data to the linear hypothesis, that is, the data is of the form: $y = a + bx$
3. You will be asked to plot a graph of the form “ y versus x ”(We say y versus x rather than x versus y because we write the equation in the form: $y = a + bx$ and we usually read from left to right.) The first variable goes along the ordinate (i.e., the vertical axis) and the second is placed along the abscissa (i.e., the horizontal axis).
4. Use a meaningful graph title. Use meaningful axis titles that include the units of measurement.
5. Use appropriate scales for the axis that are easy to read and will allow the data to most nearly fill the entire graph. Do not use categories as axis labels. If practical include the origin, that is, the point $\{0, 0\}$, at the lower left of the graph. However, the origin should be suppressed if the data is bunched a long way from zero.
6. Take a set of data points by measuring a value for y for each given value of x .
7. Draw the “best fit” straight line—the line that most nearly goes through all the points. Half the points should be above the line and half should be below the line. Do not force the line to go through the origin. (Unless $\{0, 0\}$ is a measured data point.)
8. Example graph (next page):

Calculation of Velocity

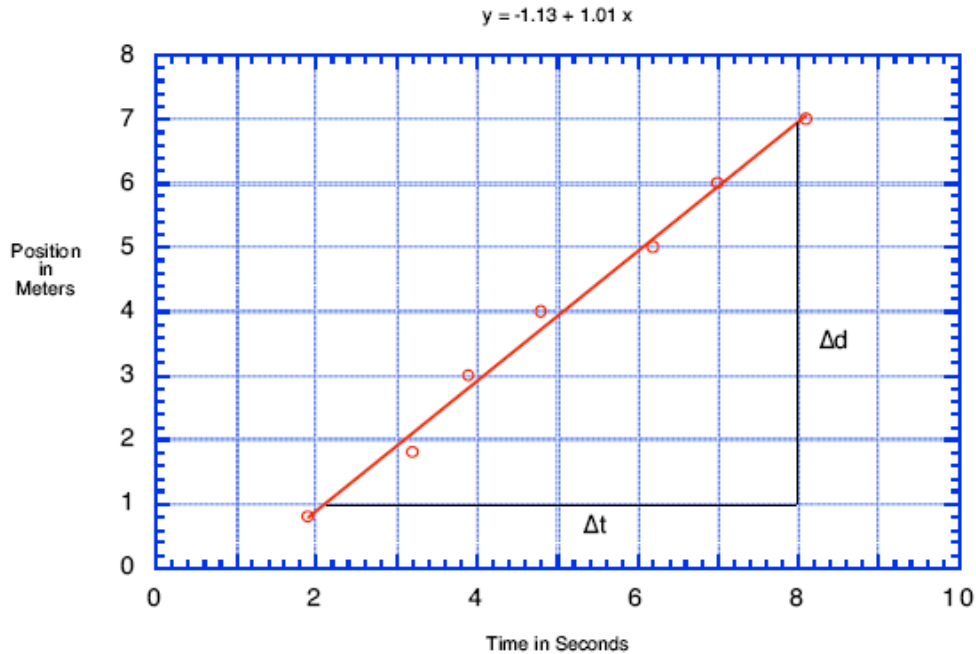

$$\text{Slope} = \frac{\Delta d}{\Delta t} = v = \frac{6.9 \text{ m} - 1.0 \text{ m}}{8.0 \text{ s} - 2.2 \text{ s}} = 1.02 \text{ m/s}$$

9. Slope calculations:

- Use a large baseline on the graph to find the Δx and Δy values
- A large baseline will increase the accuracy of your calculations
- In general you should do the slope calculations on the graph
- Draw the baseline along some convenient ordinate starting from the best-fit straight line— do not start from a data point!

10. If you use a computer-graphing package, insure that you use it correctly. Be wary of the cheap graphics packages that will graph out the x values as equally spaced categories. Do not just join the points together; you require a best-fit straight line. Insure that there are enough grid lines so that a reasonable slope calculation can be performed. Better still, use a graphics package, which does both the best-fit straight line and the slope, and intercept calculations for you. The above graph is an example as to how you are to plot acquired data. Note that the graph has the following attributes:

1. Each axis has an informative title that contains units of measurement.
2. There is a graph title.
3. The axes are computed such that the data nearly covers the complete graph.
4. There is a “best-fit” straight line that most nearly goes through all of the data points.
5. The graph is clearly linear because the data “looks” straight, and is a good linear fit because all of the data points are near the best-fit straight line.
6. Since the data is linear it can be parameterized with the following equation:

$$x = x_0 + vt$$

7. This equation is similar to the standard equation of a straight line:
 $y = a + bx$, where a is the y -intercept and b is the slope.
8. Compare the above two equations and note that the coefficients are equal, that is:
 $a = x_0$, $b = v$. The value of the y -intercept is equal to the initial position and the value of the slope is equal to the velocity.
9. The slope, which is a representation of the average velocity, has been calculated as 1.02 m/s. The best-fit data for this graph using a least-squares algorithm is printed at the top of the graph. Its value for the slope is slightly less than the calculated value, but is the more accurate value. To within two significant figures, the values for the slopes are the same, and only two significant figures were used in the slope calculation. However, it is important to keep the third significant figure for future calculations to decrease cumulative round off errors.
10. Note well, the best fit straight line does not extrapolate through the point $\{0,0\}$ and so either the initial position of the device is less than zero, or there is some distortion near zero, or else there is a systematic error.

Laboratory Report Format

The finer details of the Laboratory Report Format may vary from instructor to instructor, but each will use a format similar to that described below. The student will hand in written or typed reports. If you type the report, but do not have access to a proper equation writer, then it is better to leave blank spaces and fill in the equations by hand.

For example: $\sqrt{x + 2}$ is not the same as $\sqrt{x} + 2$, nor is x^2 an acceptable substitute for x^2 . Ambiguous equations are much worse than hand-written equations. Students are expected to use the following laboratory report format:

Group Number:

Date:

Group Members:

Object: What is to be done in this experiment.

Apparatus: Apparatus used to perform the experiment.

Theory: The calculation equations used along with meaning of the symbols and units used. Equations can be neatly hand written.

Data: Raw data in tables should be placed in this section. Sample calculations should be shown. Error calculations should be shown.

Discussion: Include a discussion of some of the sources of experimental error or uncertainty. If appropriate, should also include a comparison of various experimental errors.

For example: We found that our value of the density, within one standard deviation, has a range of 2.68 to 2.78×10^3 kg /m³. The quoted value of the density for aluminum falls

within this range, and no other material densities fall within this range, so our cylinder appears to be made of aluminum.

Conclusion: Short but comprehensive. Was the object of the experiment met?

For example: The density of the cylinder was found to be $(2.73 \pm 0.05) \times 10^3 \text{ kg/m}^3$. We selected aluminum as the material composing our cylinder because the density of aluminum, $2.70 \times 10^3 \text{ kg/m}^3$, is within the experimental error of our calculated density.

Safety Reminder

It will be necessary to follow procedures to ensure safety in each lab. Most labs do not present any significant danger, but some will require certain safety measures to be followed. The general recommendation is to follow all safety instructions, including those posted on the wall of the room you are in; if additional special safety guidelines are needed, they will be printed for each lab needing them.

Simple Harmonic Motion—The Simple Pendulum

Purpose

The purpose of this experiment is to use the apparatus for a physical pendulum to determine the dependence of the period of the pendulum on its initial angle and its length.

Introduction and Theory

The pendulum for this experiment consists of a small object, called a bob, attached to a string, which in turn is attached to a fixed point called the pivot point. The length of a pendulum is the distance from the pivot point to the center of mass of the pendulum. Since the mass of the string is much less than the mass of the bob, the length of the pendulum can be adequately approximated as the distance from the pivot point to the center of mass of the bob.

There are four obvious physical properties of the pendulum:

- the length
- the mass
- the angle
- the period

We will choose the period, that is, the time for the pendulum to go back and forth once, to be the dependent variable, and set the other physical properties to be the independent variables. If the instructor so chooses, we may also study the other properties of the pendulum as well. The period, T , of a pendulum is expressed mathematically as:

$$T = f(m, L, \theta)$$

The independent variables can strongly influence, weakly influence, or have no influence on the dependent variable. To scientifically determine the strength of the dependence, the independent variables are varied one at a time. If the varying of a physical quantity causes no variance of the dependent variable to within experimental error, then that measured physical quantity has no effect on the dependent variable. For example, if the mass of a physical pendulum is changed and the period is measured, then the data taken will produce a graph similar to the following graph (next page).

In this graph the vertical bars are called error bars. They are the one standard deviation errors in the averages for each data point. The observation that the best-fit line is horizontal and lies within all the error bars is sufficient evidence to enable one to state that the period of the pendulum is independent of its mass.

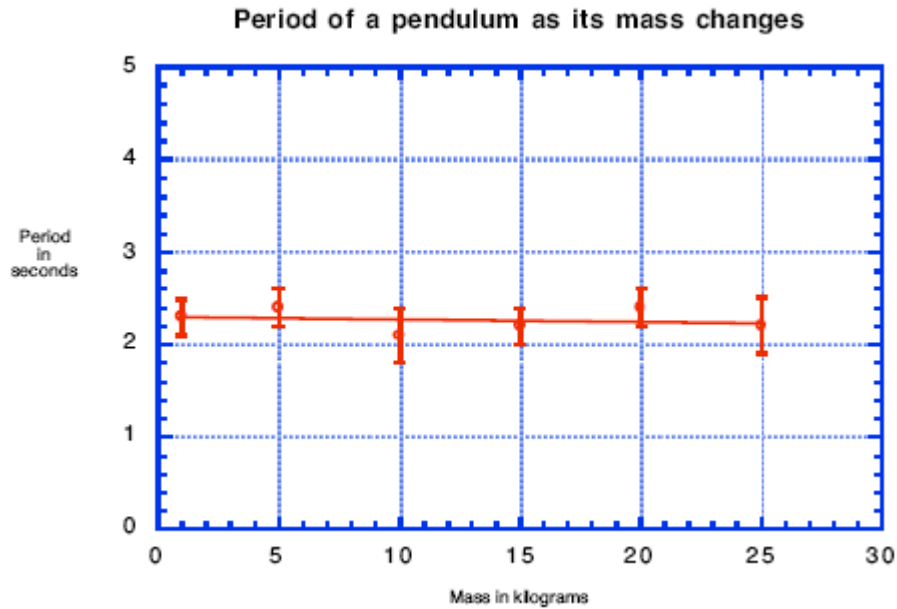

To determine the dependence of the period of the pendulum on its initial angle and its length requires two independent sets of measurements. In the first set keep the length constant while the angle is varied; in the second set keep the angle constant while the length is varied.

Equipment

Equipment Needed (Without Computer Assistance)	Qty.
Pendulum Clamp and string	1
Rod and Base	1
Meter stick	1
Protractor	1
Hooked Masses or slotted masses with mass hanger to serve as Pendulum Bob	1
Stopwatch or Lab Timer	1
Equipment Needed (With Computer Assistance)	Qty.
Brass, Aluminum, Wood, or Plastic Pendulum	1
Photo gate	1
Balance	1
Base and Support Rod	1
String	1 m
Meter Stick	1

Procedure

Without the Assistance of the Computers

1. Attach a string to the pendulum clamp mounted on the provided stand. Ensure that you understand where the pivot point is.

2. Use the following set of angles (10° , 20° , 30° , 45° , and 60°) for timing the period. When timing the period, greater accuracy can be obtained by timing for ten periods and dividing the result by 10. Use one-half the smallest scale division of your measuring device to estimate the standard deviation or uncertainty in the period of the pendulum.
3. Make a graph of period versus angle, with the one standard deviation error bars displayed for the error in the period. Does your data show that the period has a dependence on angle? Why?
4. At an angle of 20 degrees, measure the period of the pendulum for five different lengths of the pendulum. Decrease the length of the pendulum by 10 cm for each trial. When timing the period, greater accuracy can be obtained by timing for ten periods and dividing the result by 10.
5. Make a graph of period versus length, with the one standard deviation error bars displayed for the period. Does your data show that the period has a dependence on length? Why? What sort of dependence?
6. Write a report, which includes: Purpose, Apparatus, Theory, Data (raw data in tables), Graphs, Discussion (sources of error), and Conclusion.

Bonus: Show that: $T \propto \sqrt{L}$ using a graphical method.

Procedure

With the Assistance of the Computers

Please note that it may be necessary to briefly review the use of the computer as a refresher exercise. Also, one can repeat the experiment both with and without the computers and compare the results. What are the advantages and disadvantages of each approach to the experiment? If an electronic workbook is available for this experiment, you will refer to it at this time, as it will contain all the instructions needed to successfully perform this experiment; otherwise, follow the instructions below for this lab.

1. Set up the timer so that the period measured after three successive blocks of the photogate beam by the pendulum. To do this, click on the Timers button to activate the Timer Setup Window.
2. NOTE: if the electronic workbook for this lab is available, and you are directed to do so by your instructor, refer to the workbook for the remainder of the procedure. Otherwise, continue with step 3.
3. Type Pendulum Timer in the Label Box of the Timer Setup Window, then use the pick box to choose the Blocked option three times. When finished, click the Done button and the Pendulum Timer will appear in the data window.
4. Repeat Steps 2-6 in the first procedure (“Without the Assistance of the Computers”). Note that one can investigate the relationships between length and period, mass and period, and amplitude and period. In each case, the effects of air resistance are held constant, since the shape and size of the pendula are identical (not necessarily the case in the first set of procedures).

Simple Harmonic Motion—Hooke's Law

Purpose

The purpose of this lab is to understand and calculate the spring constant for a spring.

Introduction and Theory

Any material that tends to return to its original form or shape after being deformed is called an elastic material. The degree of elasticity is dependent on the internal properties of the deformed material. In many elastic materials the deformation is directly proportional to a restoring force that resists the deformation. This linear relationship is called Hooke's Law. When the deformation force is due only to gravity, Hooke's Law can be expressed as:

$$F = -ky$$

The constant of proportionality, k , is called the spring constant and gives a relative value for the stiffness of the spring. The greater the value of this constant, the greater the stiffness of the spring. In this experiment we will choose our coordinate system such that the force on the spring due to gravity can be written as:

$$F = mg = k(y_0 - y)$$

Equipment

Equipment Needed (Without Computer Assistance)	Qty.
Set of coil springs	1
Rubber band (optional)	1
Hooke's Law Apparatus (modified meter stick)	1
Slotted Weights & Weight hanger	1
Lab timers / Stopwatch	1
Lab balance	1

Equipment Needed (With Computer Assistance)	Qty.
Force Sensor	1
Motion Sensor	1
Balance	1
Base and Support Rod	1
Clamp, right-angle	1
Mass and Hanger Set	1
Meter stick	1
Spring, $k \sim 2$ to 4 N/m	1

Procedure

Without the Assistance of a Computer—note that one can use a spring of a certain k in place of the rubber band; one can also compare this with a second spring of different k .

1. Hang a spring on the meter stick/support provided and suspend a weight hanger on the rubber band. Use this as your base measurement of zero mass and y_0 . Measure y_0 from the top of the table to the bottom of the weight hanger.
2. Add masses to the spring in small increments measuring the height of the weight hanger each time.
3. Put the values in a table, which has the column headings: mass, y , and $y_0 - y$. For example:

Measurement number	Mass (m)	Distance (y)	Elongation ($y_0 - y$)
Base measurement	0	y_0	0
Trial 1	•	•	•
Trial 2	•	•	•
•	•	•	•
•	•	•	•
Trial 6	•	•	•

4. Change measured values to SI units, plot mass versus elongation for the seven measurements, (base through trial 6), and then calculate the spring constant from the slope of the graph, using the following reformulation of Hooke's Law:

$$m = \frac{k}{g}(y_0 - y)$$

5. Repeat steps 1 through 4 for the rubber band and / or a spring with a different degree of stiffness.

Procedure



With the Assistance of a Computer

(Adapted from PASCO's *Physics Labs with Computers—Teacher's Guide*, Vol. I).

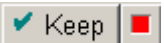
1. Set up the apparatus as shown in the diagram on the next page. The Force Sensor will have been calibrated for you. Suspend the spring from the Force Sensor's hook so that it hangs vertically.
2. NOTE: if the electronic workbook for this lab is available, and you are directed to do so by your instructor, refer to the workbook for the remainder of the procedure. Otherwise, continue with step 3.
3. Use the meter stick to measure the position of the bottom end of the spring (without any mass added to the spring). For reference, record this measurement as the spring's equilibrium position.
4. Press the tare button on Force Sensor to zero the Sensor. Start data recording. The program will begin Keyboard Sampling. Enter 0.000 in units of meters (m) because the spring is unstretched.

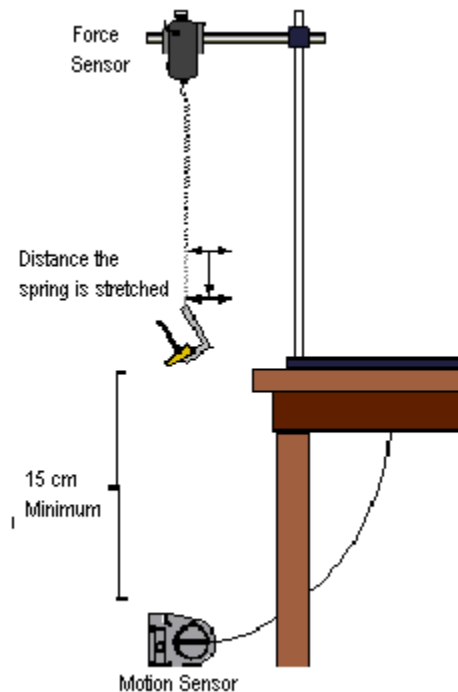
- In *DataStudio* move the table display so you can see it clearly. Click on the Start button to start recording the data. The Start button changes to a Keep and a Stop button . The Force will appear in the first cell in the Table display. Click the Keep button to record the value of the force.
- Add 20 grams to the end of the spring (be sure to include the mass of the spring) and measure the new position of the end of the spring. Enter the difference between the new position and the equilibrium position as the Δx , 'Stretch' (meters) and record a Force value for this Stretch value by clicking on the 'Keep' button.





- Add 10 grams to the spring (for a total of 30 grams additional mass) and measure the new position of the end of the spring, enter the stretch value and click 'Keep' to record the force value.
- Continue to add mass in 10-gram increments until 70 grams have been added. Each time you add mass, measure and enter the new displacement value from equilibrium and click 'Keep' to record the force value.
- End data recording by clicking on the Stop button. The data will show as Run #1.
- Determine the slope of the Force vs. Stretch graph. Click the 'Scale to Fit' button, , to rescale the graph axes to fit the data. Next, click the Fit menu button, , and select Linear. Record the slope of the linear fit in your lab report.
- Repeat the above steps for a spring of a different spring constant (stiffness).

Optional Additional Computer Assisted Activity, the Period of Oscillation:

Repeat the experiment with the Motion Sensor as shown in the above illustration.

- Remove the Force Sensor and replace the spring directly to the support rod.

2. Add 70 grams of mass to the weight hanger. Pull the mass down to stretch the spring about 20 cm (making sure it is still at least 15cm from the motion sensor), then release.
3. Begin recording data after the spring has oscillated a few times to allow any side-to-side motion to damp out. Record for about 10 seconds, then stop.
4. Make sure that the position curve resembles the plot of a sine function. If not, check the alignment between the Motion Sensor and the bottom of the mass hanger at the end of the spring. You may need to increase the size of the reflecting surface by adding a 5-cm diameter circular paper disk to the bottom of the mass hanger, then repeating the trial run.
5. To analyze the data, first rescale the graph axes to fit the data, using the Scale to Fit button () , and find the average period of the oscillation of the mass. To find this period, click on the Smart Tool button, , and move the Smart Tool to the first peak in the plot of position versus time. Read the value of time at this position and record this value in you Lab Report. Move the Smart Tool to each consecutive peak and record the value of time shown for each peak.
6. Find the period of oscillation by calculating the difference between the times for each successive peak, then finding the average of these periods. Record your result in the Laboratory Report.

Standing (Transverse) Waves using Vibrating Strings

Purpose

The purpose of this lab is to calculate the driving frequency causing standing waves on a string.

Introduction and Theory

A standing wave is composed of two waves traveling in opposite directions, which are generating an additive interference pattern.

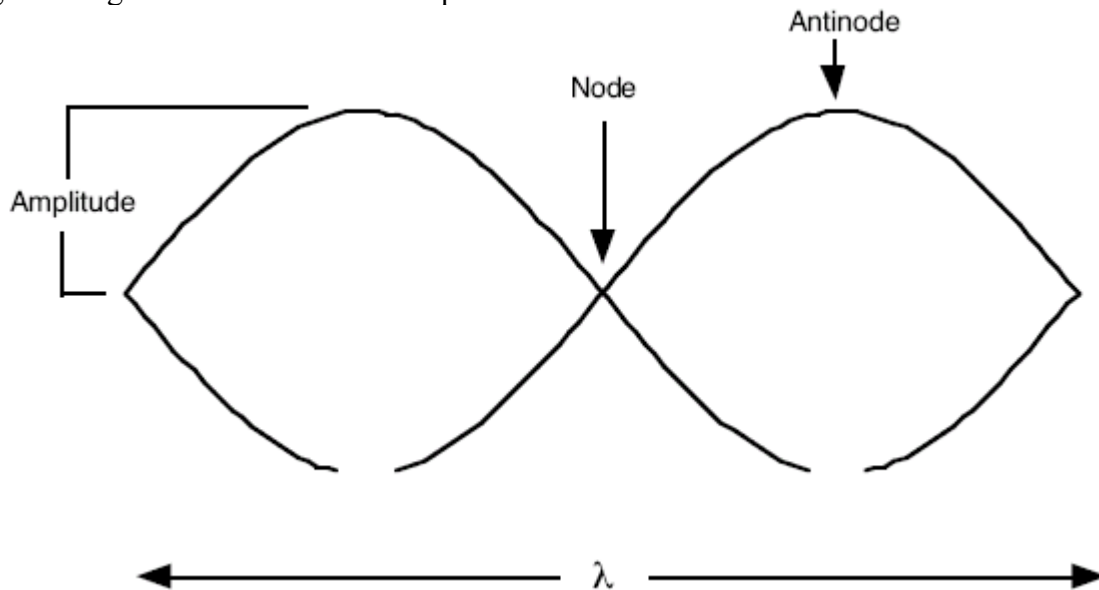

If the amplitudes are much less than the length of the string, then the speed of the wave through the string in terms of the mechanical properties of the string (inertia and elasticity) can be parameterized as:

$$v = \sqrt{\frac{F}{\mu}}$$

where v = phase velocity (the speed of the wave along the string)

$F = mg$, the tension on the string

μ = mass per unit length of the string

Wave length and frequency are related to phase velocity as: $v = \mu f$

where f = frequency (In this case, of the driving source, and so is fixed.)

λ = wave length (Note, the distance between two adjacent nodes is $\lambda / 2$)

The above two equations can be equated to obtain an equation in terms of the measurables:

$$\lambda = \left(\frac{\sqrt{g}}{f\sqrt{\mu}} \right) \sqrt{m}$$

This equation has m as the independent variable and λ as the dependent variable. It is similar in form to the equation of a straight line: $y = a + bx$. By comparison of the coefficients of the independent variable we obtain for the slope:

$$b = \frac{\sqrt{g}}{f\sqrt{\mu}}$$

Solving for the frequency, we find:

$$f = \frac{\sqrt{g}}{b\sqrt{\mu}}$$

where f = driving frequency
 μ = mass per unit length
 b = slope of the best fit line for λ versus m
 $g = 9.80 \text{ m / s}^2$

Equipment

Equipment Needed	Qty.
Electronic String Vibrator	1
Clamps & Support Rod	1
Pulley with rod support	1
Strings	1
Weight Hangers & Slotted Weights	1
Laboratory Balance	1
Cartesian graph paper	1 Sheet

Procedure

1. The instructor will give you the mass per unit length of the string.
2. How would you determine the mass per unit length of the string?
3. Use the apparatus to generate a table of wavelength versus hanging mass. Vary the amount of mass on the weight hanger to find maximum amplitudes for each of 2 nodes, 3 nodes, . . . , 6 nodes. Measure the associated wavelengths. Remember that the wavelength is the distance between any two nodes or antinodes.
4. Plot a graph with wavelength on the ordinate and the square root of the mass on the abscissa.
5. Draw a best-fit "average" line through the points.
6. Using a large baseline, find the slope of the graph. Do not use data points to find the slope!
7. Calculate the frequency of the driving source. Use the slope of the graph in this calculation. Do not use some arbitrary set of data points!

8. Correctly write your results in SI units. Compare with the expected result of either 60 or 120 Hertz. Is your value within experimental error of one of the expected results?
10. Remember the lab report is to consist of: Group, date, purpose, apparatus, theory, data, graph, discussion, and conclusion.
11. The discussion should include sources of error and an answer to the question in step two.

Bonus Question:

Stringed musical instruments, such as violins and guitars, use stretched strings to create musical tones. Use the following equation as reference (and any previous equations, if necessary) to explain:

- a. How tightening and loosening the strings tune them to their designated tone pitch.
- b. Why the strings of lower tones are thicker or heavier than strings of higher tones.

$$F = (\lambda f)^2 \mu$$

The Speed of Sound in Air

(Adapted from Jerry Wilson, *Physics Laboratory Experiments*, 4th Ed, pp. 227-230, © 1994 Houghton Mifflin Company)

Purpose

The purpose of this experiment is to use resonance to measure the speed of sound in air.

Background and Theory

Air columns in pipes or tubes of fixed lengths have particular resonant frequencies. An example is an organ pipe of length L with one end closed, the air in the column, when driven at particular frequencies vibrates in resonance. The interference of the waves traveling down the tube and the reflected waves traveling up the tube produces longitudinal standing waves, which have a node at the closed end of the tube and an antinode at the open end.

The resonance frequencies of a pipe or tube depend on its length L . Only a certain number of wavelengths can “fit” into the tube length with the node-antinode requirements needed to produce resonance. Resonance occurs when the length of the tube is nearly equal to an odd number of quarter wavelengths, i.e. $L = \lambda / 4$, $L = 3\lambda / 4$, $L = 5\lambda / 4$, or generally $L = n\lambda / 4$ with $n = 1, 3, 5, \dots$ and $\lambda = 4L / n$. Incorporating the frequency f and the speed v_s through the general relationship $\lambda f = v$, or $f = v/\lambda$, we have

$$f_n = \frac{nv}{4L} \quad n = 1, 3, 5, \dots$$

Hence, an air column (tube) of length L has particular resonance frequencies and will be in resonance with the corresponding odd-harmonic driving frequencies.

As can be seen in this equation, the three experimental parameters involved in the resonance conditions of an air column are f , v , and L . To study resonance in this experiment, the length L of an air column will be varied for a given driving frequency, instead of varying f for a fixed L as in the case of the closed organ pipe described above. Raising and lowering the water level in a tube will vary the length of an air column.

As the length of the air column is increased, more wavelength segments will fit into the tube. The difference in the tube (air column) lengths when successive antinodes are at the open end of the tube and resonance occurs is equal to a half wavelength; for example,

$$\Delta L = L_2 - L_1 = \frac{3\lambda}{4} - \frac{\lambda}{4} = \frac{\lambda}{2} \quad \text{and} \quad \Delta L = L_3 - L_2 = \frac{5\lambda}{4} - \frac{3\lambda}{4} = \frac{\lambda}{2} \quad \text{for the next resonance.}$$

When an antinode is at the open end of the tube, a loud resonance tone is heard. Hence, lowering the water level in the tube and listening for successive resonances can determine the tube lengths for antinodes to be at the open end of the tube. If the frequency f of the

driving tuning fork is known and the wavelength is determined by measuring the difference in tube length between successive antinodes, $\Delta L = \lambda / 2$ or $\lambda = 2\Delta L$, the speed of sound in air v_s can be determined from $v_s = \lambda f$.

Once v_s is determined (for a given ambient temperature), the unknown frequency of a tuning fork can be computed from the first equation using the experimentally determined resonance wavelength in an air column for the unknown tuning fork frequency. The speed of sound, which is temperature dependent, is given to a good approximation over the normal temperature range by $v_s = 331.5 + 0.6T_c$ m / s, with T_c the air temperature in degrees Celsius.

Equipment

Equipment Needed (Without Computer Assistance)	Qty.
Resonance tube apparatus	1
Tuning Forks (500 – 1000 Hz) stamped Frequency of 1 fork should be covered/unknown	3
Rubber mallet or Block	1
Meter stick	1
Thermometer	1
Vernier Calipers	1
Rubber Bands	4

Equipment Needed (With Computer Assistance)	Qty.
Sound Sensor	1
Base and Support Rod	1
Clamp, three-finger	1
Tape Measure	1
Tape, duct	some
Tube, cardboard, 15 cm diameter	1

Procedure

Without the assistance of the Computer

1. With the upright resonance tube apparatus, measure the inside diameter (I.D.) of the tube with a Vernier caliper and record this along with the room temperature in your lab report.
2. Place several rubber bands around the tube at various heights. These will be used to mark resonance positions later in the experiment. Raise the water level to near the top of the tube by raising the reservoir can, by depressing the can clamp and sliding it on the support rod. With the water level near the top of the tube, there should be little water in the can; if this is not the case, remove some water from the can to prevent overflow and spilling when the can becomes filled when lowering.
3. With the water level in the tube near the top, take a tuning fork of known frequency and set it into oscillation by striking it with a rubber mallet or on a rubber block. Hold the fork so that the sound is directed in the tube (experiment with the fork and your ear to find the best orientation). With the fork above the tube, quickly lower the reservoir can. The water in the tube should slowly fall at this time, and successive

- resonances will be heard as the level passes through the resonance length position. It may be necessary to strike the fork several times to keep it vibrating sufficiently
4. As the water passes through these levels of resonance, mark their approximate locations with the rubber bands. Repeat the procedure, adjusting the rubber band heights until you are satisfied that the rubber bands are at the heights for the water levels where the resonances are obtained.
 5. Determine the length from the top of the tube for the first resonance condition and record this length in your lab report. Repeat this position for the other observed resonance positions. Repeat steps 3 to 5 with the other tuning fork of known frequency.
 6. Finding the speed of sound and experimental error:
 - a. Compute the average wavelength for each fork from the average of the differences in the tube lengths between successive anti-nodes.
 - b. Using the known frequency for each fork, compute the speed of sound for each case.
 - c. Compare the average of these two experimental values with the value of the speed of sound given by the last equation by computing the percent error (if this error is large, you may have observed the resonances of the tuning forks' overtone frequencies—consult your instructor in this case).
 7. Repeat Procedures 3 through 5 for the tuning fork of unknown frequency. Compute the frequency of this tuning fork using the average experimental value of the wavelength and the speed of sound as given by the speed of sound equation.

Procedure

With the assistance of the Computer

(Adapted from *Physics Labs with Computers*, PASCO, pp. 261-263)

1. If an electronic workbook is available for this experiment, and you are instructed to do so, go to the e-workbook at this time and follow the instructions included therein. If not, proceed with the following:
2. Take a tube with one end closed and, using a support rod and clamp, mount the Sound Sensor in the middle of the open end of the tube. Measure the length of this tube and record this in the Data Table.
3. Start monitoring data by selecting 'Monitor Data' from the Experiment menu. Snap your fingers in the open end of the tube and watch the results on the Scope display. (If the first trace of data does not show the snapping sound and its echo, adjust the sweep speed in the scope display).
4. Click 'Stop' to stop monitoring data.
5. Transfer the data from the Scope display. To do so, click the 'Transfer Data' button in the Scope toolbar. Result: the data run appears under 'Data' in the Summary List
6. View the data in the Graph display. In the Graph display, select the run of data from the 'Data menu'. Result: the Graph display shows the sound and its echo.
7. Use the built-in analysis tool of the Graph display to find the time between the first peak of the sound and the first peak of its echo. Calculate the speed of sound. Use the 'delta function' of the Smart Tool . Click and drag the corner of the Smart Tool from the first peak of the sound to the first peak of the echo.

Coefficient of Linear Expansion of Metals

Purpose

The purpose of this lab is to directly observe the lengthening of a metal rod as it is heated.

Background and Theory

The dimensions of most metals increase with an increase in temperature. For nominal temperature changes, the change in length of a given length of material is proportional to both the original length L_0 and the change in temperature ΔT of the material. The fractional change in length per degree change in temperature is called the coefficient of linear expansion of that material. The formula for the coefficient of linear expansion, “ α ”, may be written as:

$$\alpha = \frac{\Delta L}{L_0 \Delta T}$$

where: L_0 = initial length of the rod
 ΔL = change in length of rod
 ΔT = change in temperature

Some coefficients of linear thermal expansion are:

Aluminum	$24.0 \times 10^{-6} \text{ }^\circ\text{C}^{-1}$
Brass	$18.8 \times 10^{-6} \text{ }^\circ\text{C}^{-1}$
Copper	$16.8 \times 10^{-6} \text{ }^\circ\text{C}^{-1}$
Iron	$11.4 \times 10^{-6} \text{ }^\circ\text{C}^{-1}$
Steel	$13.4 \times 10^{-6} \text{ }^\circ\text{C}^{-1}$

Equipment

Equipment Needed (Without Computer Assistance)	Qty.
Meter stick	1
Linear (Thermal) Expansion Apparatus and Tubing	1
Metal Rods: Aluminum, Brass, Copper, Steel	1 of each
Digital Multimeter or Ohm-meter with Banana-type Connectors	1
Thermometer (Optional)	1
Bunsen Burner, stand, and Steam Generator, or Electric Steam Generator	1
Equipment Needed (With Computer Assistance)	Qty.
Thermistor Sensor	1

Linear (Thermal) Expansion Apparatus and Tubing	1
Metal Rods: Aluminum, Brass, Copper, Steel	1 of each
Rotary Motion Sensor	1
Bunsen Burner, stand, and Steam Generator, or Electric Steam Generator	1

Procedure

The procedure to calculate α is (*note that a computerized version of this lab is currently under construction and is not included here, refer to the instructor for details*):

1. Measure the length of the rod using the meter stick. The temperature at this point is the room temperature.
2. Mount a metal rod inside the steam jacket such that it is supported at either end by cork stoppers and calibrate the Vernier measuring device on the end of the holder. Move the screw in until it just touches. Do this five times and take a standard deviation. Use this value for the cold part of the ΔL .
3. Connect the “in” tube to the boiler. The boiler should be about 1/3 full of water and connected to the steam jacket. The out tube must remain open and should be routed to a sink or beaker to catch the water condensing from the escaping steam.
4. Insert the thermometer and take the initial temperature of the apparatus.
5. Loosen the screw on the Vernier measuring device. Light the Bunsen burner. Begin heating the water. Allow steam to flow through the jacket for about 5 minutes until the system has come to equilibrium. What can you use to determine that the system has come to equilibrium?
6. Tighten the setscrew as before to get a new set of readings of the length of the rod.
7. Measure the final temperature of the rod. Is this temperature the same as the expected temperature of steam?
8. Of what material is the rod made? That is, is the calculated value of α within experimental error of any of the values in the table?
9. Remember the lab report is to consist of: Group, date, purpose, apparatus, theory, data, sample calculations, discussion (including sources of error), and conclusion.

Bonus: If flat strips of iron and brass were bonded together along the flat sides and then the resulting bimetallic strip is heated, what would be observed? Justify your answer and draw a sketch of the before and after situations.

Calorimetry: the Melting of Ice (Heats of Fusion and Vaporization of Water)

Purpose

The purpose of this lab is to understand how to work with phase changes in materials.

Background and Theory

In this experiment we will study the phase change of ice into water. If one places two systems that have different temperatures in contact with each other, then after some finite time the temperature of the new system comes to a new value somewhere between the two original values. This process of temperature redistribution is done through the transfer of heat. The amount of heat that causes a given temperature change for a given mass depends on the type of substance heated. The amount of heat that a substance can hold per unit mass is called specific heat. This specific heat depends on the material of which the substance is composed. We define specific heat as follows:

$$c = \frac{\Delta Q}{m\Delta T} \text{ (in units of J / (kg}\cdot\text{K))}$$

Where: c = specific heat

ΔQ = change in heat

m = mass of substance

ΔT = change in temperature for a given change in heat

The specific heats of substances are not constant but depend on the location of the temperature interval and how the substance is heated. At room temperatures and for reasonable changes about room temperature, specific heats of solids or liquids can be considered approximately constant. Specific heat also depends on pressure, but this will not be a concern in this lab. Since heat is just a form of energy we will use the SI unit for energy, the Joule (J), as the unit of heat. Some values of specific heats in J / (kg•K) at standard temperature and pressure are:

water	= 4180
ice	= 2220 (at 263 K)
glass	= 840
styrofoam	≈ 100

Since heat is a form of energy, we can invoke the principle of conservation of energy. That is: Heat Lost = Heat Gained, or more explicitly:

$$-\Delta Q_H = \Delta Q_C \quad \text{where H = hotter, C = cooler}$$

A substance going from one physical state to some other physical state goes through what we call a change in phase of the substance. Ice going to water, or water going to steam, are examples of phase changes. A change of phase takes energy. When ice melts to water,

and both pressure and temperature are held constant, the energy to change the ice to water comes from adding heat. The heat of fusion for the phase change of ice to water is:

$$\Delta Q_f = mL_f \quad \text{where } L_f = 335,000 \text{ J / kg.}$$

The processes of ice warming, ice melting, and then the warming of ice water to equilibrium all occur sequentially. Since the melting of ice is a reversible process we can treat the mathematics as if each process occurs separately and so can break the problem into three parts:

- Heating of the ice to 0°C. (Remember $K = 273.15 + ^\circ C$)
- Melting the ice to water. ($\Delta T = 0$)
- Heating the ice water to the equilibrium temperature.

Equipment

Equipment Needed	Qty.
Thermometer (0-110 C) or Temperature Sensor	1
Ice	Some
Paper Towels	3 sheets
Lab balance	1
Beakers	1

Procedure

For this experiment we will melt some ice and then try to calculate the original temperature of the ice. It is necessary to accomplish many of the following steps quickly but carefully. The procedure is:

1. Use at least three significant figures in your measurements.
2. Determine the mass of the container that you will be using to hold the water in which to melt the ice.
3. Fill the container with warm water (~30°C). Then find the mass of the container with the water in it.
4. Use a paper towel to get a couple of ice cubes. Measure the mass of the ice cubes and towel. Measure the temperature of the water just before dropping the ice into the water. Try not to splash any water out of the container. Why is there this need to be careful? Estimate the third significant figure on the thermometer to within ± 0.2 degrees.
5. Measure the mass of the paper towel as soon as possible after the ice has been placed in the water container. Why?
6. Stir the water gently until the ice has melted. When the mercury in the thermometer reaches a minimum, record this temperature as your measured equilibrium temperature. (Note well: the minimum occurs sometime after the ice is melted.)
7. Now calculate the initial temperature of the ice by applying the principle of conservation of energy. (The correct SI temperature unit is K, not °C.)

$$-\Delta Q_H = \Delta Q_i + \Delta Q_f + \Delta Q_m$$

- Expand this equation in terms of the definitions of heat and then solve for the initial temperature of ice. The changes in temperature are best determined by subtracting the initial temperature from the final temperature. The subscripts refer to:
 - H = hotter system, which includes both the water and container.
 - i = ice, the increase of ice from its initial temperature to 0°C.
 - f = fusion, the phase change of the ice to water.
 - m = mixing, the mixing of the 0°C ice water with the large mass of water and container.
 - We assume that the heat transfer from the surroundings into the container is small. This is true if the container is placed on a non-conductor of heat. The heat absorbed by the ice while it is melting is equal to the heat lost by the container and the water it contains. (It is the amount of heat that is conserved, not the temperature.)
8. What is a major source of systematic error in this experiment?
 9. What is a major source of random error in this experiment?
 10. Calculate which of the three terms in the energy equation absorb the most heat?
 11. Write up your report using the standard format. Be sure to include all of your measurements in a data table. In the discussion section of your report be sure to answer all of the questions.

Bonus: Find the value of T_i where the heat absorbed by warming the ice to 0°C does as much to cool the water as is absorbed into the heat of fusion.

Boyle's Law: Finding Absolute Zero (Gay Lussac's Law)

(Adapted from PASCO, *Physics Labs with Computers*, Vol. 1, pp. 155-172)

Purpose

The purpose of this exercise is to determine the absolute zero point and find the relation between pressure, volume, and temperature in a gas.

Background and Theory

Boyle's law states that the pressure of a gas in a container is related to the volume of the gas. In other words, as the volume changes, the pressure changes. For a given amount of a gas at a fixed temperature the pressure of the gas is inversely proportional to the volume. One way to verify this is to graph the inverse of gas volume versus gas pressure.

The most common states of matter found on Earth are solid, liquid and gas. The only difference among all these states is the amount of movement of the particles that make up the substance. Temperature is a measure of the relative movement of particles in a substance because temperature is a measure of the average kinetic energy of the particles. At any specific temperature the total kinetic energy is constant. Particles with a large kinetic energy tend to collide frequently and move apart. Intermolecular forces tend to pull particles toward each other. The forces that bind some molecules together at a particular temperature are greater than the kinetic energy of the molecules.

In an "ideal gas" there are no intermolecular forces. In fact, the "ideal gas" has no mass and occupies no volume. While the "ideal gas" is fictional, real gases at room temperature and pressure behave as if their molecules were ideal. It is only at high pressures or low temperatures that intermolecular forces overcome the kinetic energy of molecules and the molecules can capture one another.

For an "ideal gas", the volume of the gas is inversely proportional to the pressure on the gas at a constant temperature. In other words, the product of the volume and pressure for the gas is a constant when the gas is at a constant temperature.

$$PV = k$$

At the same time, the volume of gas is proportional to the temperature. If a gas is heated, the volume of the gas increases. If it is cooled, the volume of the gas decreases, thus:

$$V = Tk_2 \text{ or}$$
$$\frac{V}{T} = k_2$$

At very low temperatures, the intermolecular spacing decreases for real gases, as the forces between the molecules overcome kinetic energy. The gas becomes a liquid. At still lower temperatures and higher pressures, the liquid is forced into a rigid structure we call

a solid. For the “ideal gas”, this gas would continue to have a constant pressure-volume relationship. For the “ideal gas”, as the temperature decreases, the volume and the pressure of the gas also decrease, with the pressure and volume maintaining a constant relationship.

Theoretically, one can use a graph of pressure versus temperature to estimate the value of Absolute Zero by finding the temperature that the pressure reaches zero.

Equipment

Equipment Needed	Qty.
Pressure Sensor coupling, quick-release	1
Temperature Sensor	1
Scholar 170 hot plate or other heating device	1
Absolute Zero Apparatus	1
Syringe (w/ sensor)	1
Tubing (w/ sensor)	1
Glycerin	1 mL
Base and Support Rod	1
Beaker, 1.5 L	4
Buret Clamp	1

Procedure

Note: Steps 2a through 2g, along with 3 make up an optional computer-assisted demonstration exercise to complement the current lab while the water is heating up for the main experiment. Performing the demonstration will add to the understanding gained in the main exercise.

1. Put about 800 mL of water into a 1.5 beaker and put the beaker on the hot plate. Start to heat the water (it may not reach boiling in the time allotted, but this is okay for experimental purposes).
2. While waiting for the water to heat up, use the Pressure Sensor to measure the change in pressure of the air in a syringe as you change the volume, while using *DataStudio* to record and analyze the data.
 - a. Put a drop of glycerin on the barb end of the quick release coupling. Put the end of the coupling into one end of a short piece (about 2.5 cm) of plastic tubing that comes with the Pressure Sensor.
 - b. Put a drop of glycerin on the end of the syringe, and then connect the end of the syringe to the other end of the small piece of plastic tubing.
 - c. Align the quick-release coupling on one end of the plastic tubing with the pressure port of the Pressure Sensor. Push the coupling onto the port, and then turn the coupling clockwise until it clicks (about one-eighth turn).
 - d. Check that the syringe and the Pressure Sensor have a secure seal by adjusting the volume between 20 mL and 10 mL—it should get harder to push as the volume decreases.
 - e. Adjust the volume of air in the syringe to 20.0 mL. (Note: To set the initial position of the piston in the syringe, disconnect the quick-release connector from the sensor, move the piston to the first position (20mL) and then re-connect the quick-release connector to the sensor.)
 - f. To record the data in *DataStudio*:
 - i. Start recording data when everything is ready (click Start).

Ohm's Law

Purpose

The purpose of this lab is to show that Ohm's Law is valid.

Background and Theory

When a voltage is placed across a conductor then current flows through that conductor. The amount of current that flows depends on the material of the conductor and the temperature of the conductor. If we assume that the temperature of the conductor to be constant then the flow of electrons is proportional to the voltage applied. That is:

$$V \propto I, \text{ or } V = RI$$

where the dependent variable V is the electric potential or voltage, the independent variable I is the current, and the constant of proportionality, R , is called the resistance. If a material obeys Ohm's Law then the measured resistance of the material should be a constant independent of voltage and current (or nearly so). This means that if a plot of V versus I for a given material is a straight line, then the material is said to obey Ohm's Law and the slope of that line is the resistance, R , of the material. In order to show that the above equation is a valid representation of a physical process we will perform the following experiment.

The standard units used in electrical measurements are:

<i>Quantity</i>	<i>Symbol</i>	<i>Unit</i>
Electric Potential	V	Volt (V)
Current	A	Ampere (A)
Resistance	R	Ohm (Ω)

Current measurements will often be made in mA. Be sure to change these values to Amperes before graphing or using them in equations. (Note that the unit of resistance is such that $1 \Omega = 1 \text{ V} / \text{A}$.)

Equipment

Equipment Needed	Qty.
Ammeter (0-0.5 A, or Current Sensor)	1
Voltmeter (0-10V, or Voltage Sensor)	1
Decade resistance box (0.1*99.9 Ω)	1
Cartesian graph paper	2 sheets
The following components can be substituted by PASCO's AC/DC Electronics Laboratory System	
Rheostat (200 Ω)	1
Battery or power supply	1
Connecting wires	1
Switch	1

Safety Reminder

Caution: Be very careful in the use of the meters. Start with the rheostat fully on and use the largest scale on the meter. Failure to follow this procedure could result in damage to the meters.

Procedures

1. Set up the apparatus as in the following diagram:

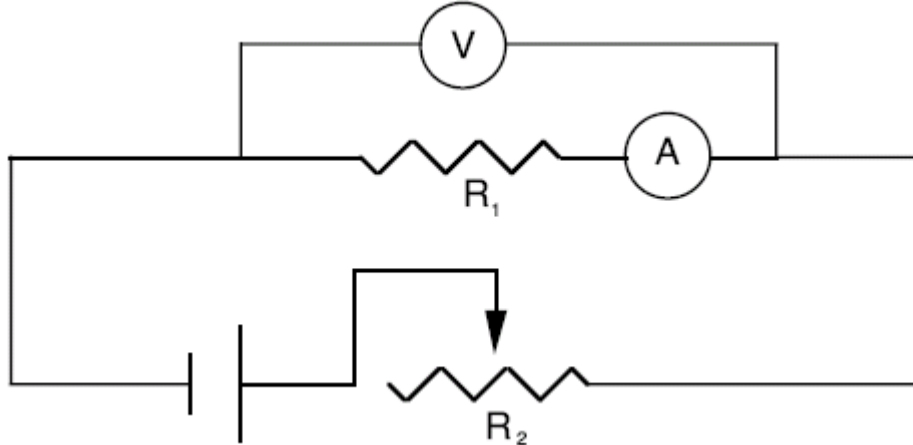

A = Ammeter
V = Voltmeter
 R_1 = Load Resistor
 R_2 = Rheostat

2. Vary the circuit current using the rheostat while keeping the load resistance constant. Measure the value of V and I for at least 6 different values of V .
3. Use the multimeter to measure the value of R_1 . The measurement error using the multimeter is ± 3 in the least significant digit displayed on the multimeter.
4. Then plot V vs I . (On a sheet of quadrille lined graph paper. Use the whole sheet!)
5. From the graph, do you think that V is linearly proportional to I ? If so, why?
6. From the graph calculate the resistance of the resistor.
7. Compare the calculated value with the measured value of the resistance. Do they have the same value to within experimental error?
8. Did you show that Ohm's Law is valid?
9. Remember the lab report is to consist of: Group, date, purpose, apparatus, theory, data, graph, discussion, and conclusion.

Bonus: How would the measurements be affected if the components were to heat up?

Series and Parallel Circuits

Purpose

The purpose of this lab is to learn how currents flow through simple linear series and parallel circuits.

Background and Theory

Schematic for a Series Circuit:

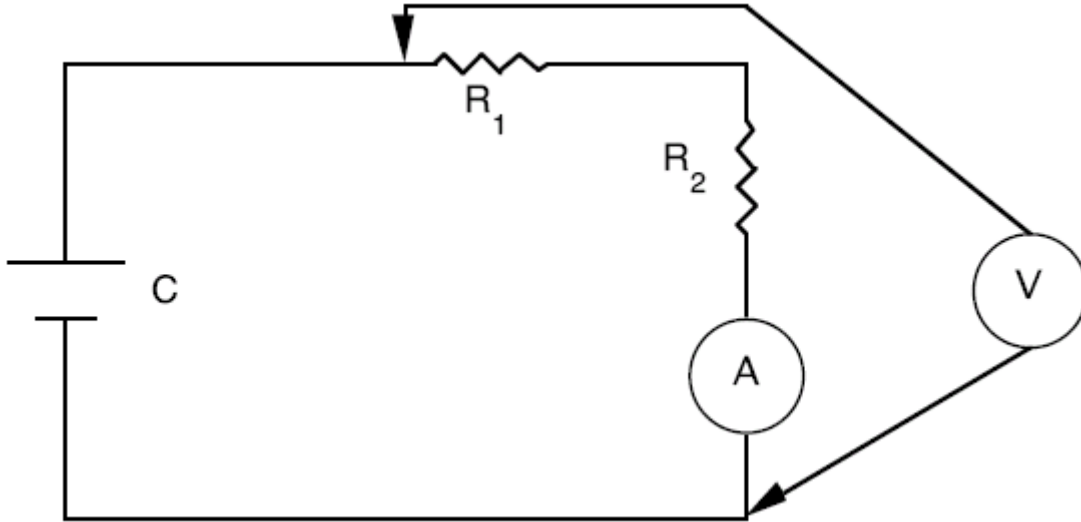

C = battery cell
A = ammeter
R₁ = resistor one
R₂ = resistor two

When some number of resistors is arranged in a circuit hooked together in a series connection as in the above diagram, then the following conditions hold:

1. The current in the circuit must everywhere be the same.
2. The sum of the voltage drops across the separate resistors must equal the applied voltage:

$$V_T = V_1 + V_2 + V_A$$

3. The total resistance in the circuit is the sum of the individual resistances. Note well, the ammeter has an internal resistance that needs to be included in this experiment.

$$R_T = R_1 + R_2 + R_A$$

When a set of resistors are arranged in parallel as in the diagram below, then the following holds:

1. The voltage drop across the resistors is the same, independently of the values of the resistors, and is called the load voltage.

- The total current into the parallel part of the circuit is equal to the sum of the currents in each branch of the parallel circuit.
- The total resistance for resistors in parallel is:

$$R_T = \frac{1}{\sum_{i=1}^n \frac{1}{R_i}}$$

Schematic for a Parallel Circuit:

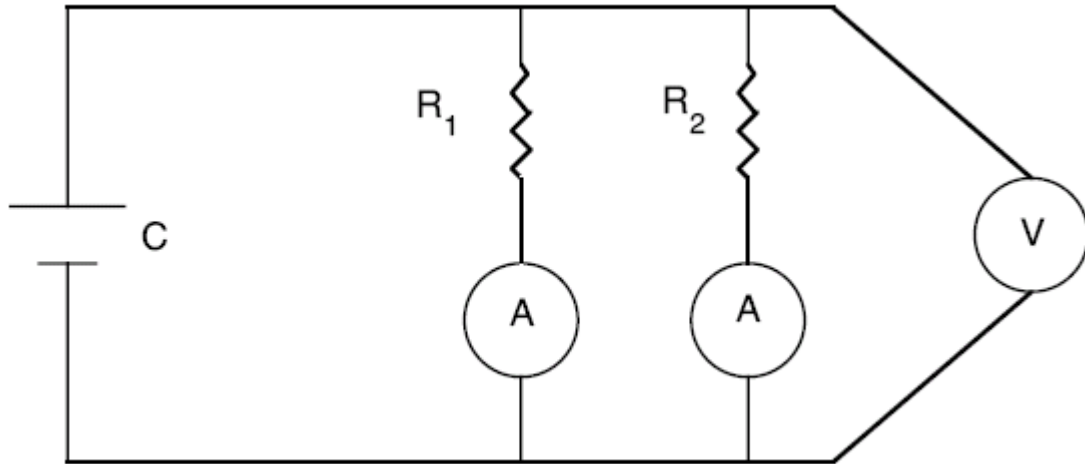

C = battery cell
 A = ammeter
 V = voltmeter
 R₁ = resistor one
 R₂ = resistor two

Equipment

Equipment:	Qty.
The following components can be used as is or substituted by PASCO's AC/DC Electronics Laboratory System	
Battery or Power supply	1
Ammeter (0 – 500 mA, or Current Sensor)	1
Single pole, single throw switch	1
Resistors (10 Ω, 20 Ω, 100 Ω, 10k Ω)	1 of each
Voltmeter (0 to 3V)	1 of each

Procedures

For the Series Circuit—

To show that the resistance formula on the previous page is valid set up the apparatus as in the series circuit diagram and then:

- When using the multimeter try for at least three significant figures.
- Measure the voltage drops across each of the resistors and the ammeter.
- Measure the closed circuit voltage across the battery.

4. Remove the wires from the battery and measure the total resistance of the circuit by placing the ohmmeter leads on these two wires. This is often called the open circuit resistance.
5. Measure the resistance of each resistor and ammeter.
6. Is the measured resistance the same as the calculated resistance to within experimental error?
7. Does the ammeter resistance have any practical effect in your circuit? Why?

For the Parallel Circuit—

To show that the equation for resistors in parallel is valid, set up the apparatus for parallel circuits as in the above diagram:

1. Measure the voltage drop across the resistors. Is it the same for each resistor? Why should it be the same?
2. Measure the current in each branch of the parallel circuit. Calculate the total resistance of the circuit:

$$R_T = \left(\frac{I_1}{V_1} + \frac{I_2}{V_2} \right)^{-1}$$

The error in the total resistance is:

$$\sigma_{R_T} = R_T^2 \sqrt{\left(\frac{1}{V_1^2} + \frac{1}{V_2^2} \right) \sigma_I^2 + \left(\frac{I_1^2}{V_1^4} + \frac{I_2^2}{V_2^4} \right) \sigma_V^2}$$

3. Measure the open circuit resistance. Removing the wires from the battery and measuring the resistance between the two wires best achieve this. Then measure the resistance of each resistor. Calculate the total resistance and then the error in the resistance using the following formulas.

$$R_T = \frac{R_1 R_2}{R_1 + R_2} \quad \sigma_{R_T} = (R_T)^2 \sqrt{\frac{\sigma_{R_1}^2}{R_1^4} + \frac{\sigma_{R_2}^2}{R_2^4}}$$

Is this equal to the measured total resistance to within experimental error?

4. Are the values for resistance calculated in part 3 equal, to within experimental error, to the value for resistance calculated in part 2?

Remember the lab report is to consist of: Group, date, purpose, apparatus, theory, data, discussion (including some sources of error and answers to questions), and conclusion.

Bonus: When two resistors are connected in parallel, the total resistance is less than the value of either resistor. Use boundary conditions to algebraically find the ratio, R_1 / R_2 that produces the maximum decrease in the value of the total resistance, R_T . (Hint: There exists three useful boundary conditions to examine.)

Resistivity

(Adapted from Jerry Wilson, *Physics Laboratory Experiments*, 4th Ed., pp. 353-357, © 1994 Houghton Mifflin Company)

Purpose

The purpose of this experiment is to investigate the resistivity of several different types of wires.

Background and Theory

The resistance of an electrical conductor depends on several factors, such as its physical shape, the type of material it is made of, and the temperature. The resistance of a wire is directly proportional to its length l and inversely proportional to its cross-sectional area, A :

$$R \propto \frac{l}{A}$$

An analogy for this is the flow of water through a pipe. The longer the pipe, the more resistance to flow, but the larger the cross-sectional area of pipe, the greater the flow rate or the smaller the resistance to flow. The material property of resistance is characterized by the resistivity ρ , and for a given temperature:

$$R = \frac{\rho l}{A}$$

Resistivity is independent of the shape of the conductor, and rearranging the previous expression gives the equation for resistivity:

$$\rho = \frac{RA}{l}, \text{ with units of } \Omega\text{-m or } \Omega\text{-cm}$$

Equipment

Equipment Needed	Qty.
Ammeter (0-0.5 A)	1
Voltmeter (0-3V)	1
Rheostat (20 Ω)	1
Battery or power supply	1
Single pole, Single throw switch	1
Meter stick	1
Micrometers or Calipers	1
Conductor board or wires of various types, lengths and diameters	1 (set)

Procedure

1. Set up the circuit as shown below, with one of the wires on the conductor board in the circuit. Leave the switch open, the rheostat set to the maximum resistance, and have the instructor check the circuit before activating.
2. Close the switch and adjust the rheostat until the current in the circuit as indicated by the ammeter is 0.5 A. Record the meter values and open the switch as soon as possible to prevent heating and temperature change.
3. Measure the length of the wire between the voltmeter connections and the diameter of the wire.
4. Test the effect of length by changing the length of the wire being tested to about 0.50 m. This can be done by moving one of the voltmeter contact points and repeating the measurements.
5. Return the rheostat to the maximum resistance and repeat the procedure for the other wires on the board.
6. Compute the resistances and cross-sectional areas of the wires, and use these values to determine the resistivities of the materials. Find the average resistivity for each material with more than one experimental value.
7. Find the percent error of the experimental values by comparing your values with the accepted values listed below

NOTE: For best results, the voltmeter should make contact with the resistance wire (R) about 5 cm in from the terminals, not at the terminals. Also, the copper wire on the conductor board should be a single piece zig-zagging back and forth across the board so that readings can be taken with various lengths of this wire.

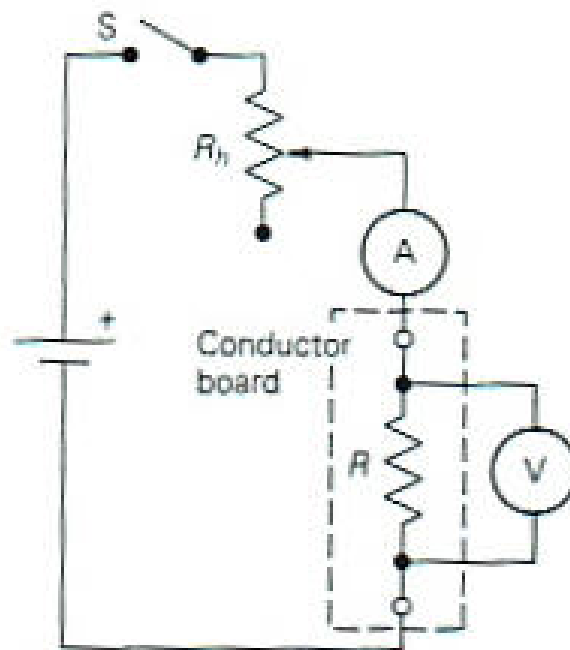

Substance	Resistivity, ρ (Ω-cm)
Aluminum	2.8×10^{-6}
Brass	7×10^{-6}
Constantan	49×10^{-6}
Copper	1.72×10^{-6}
German Silver (18% Ni)	33×10^{-6}
Iron	10×10^{-6}
Manganin	44×10^{-6}
Mercury	95.8×10^{-6}
Nichrome	100×10^{-6}
Nickel	7.8×10^{-6}
Silver	1.6×10^{-6}
Tin	11.5×10^{-6}

Computer Experiment Simulation (Thermodynamics, Electricity & Magnetism, Optics, or Modern)

Introduction

One of the many conveniences of computers is their powerful ability to simulate natural phenomena. Computer simulations save scientists billions of dollars per year by avoiding expensive experiments in wind tunnels and blast chambers as two examples. Computer simulations can be performed to simulate a phenomenon that we cannot readily access, such as the gas flows inside a star in the process of going supernova, the fluctuations of an atom, and the evolution of a solar system over billions of years' time. Back on Earth, much simpler simulations can be used in the classroom to repeat live experiments using an array of initial conditions, enabling students to see clearly how changing parameters can change the outcome of an experiment.

In this Lab, we are going to run such a simulation. The assignment (which will vary by instructor and class section) is to select an experiment of your choosing in the areas of Thermodynamics, Electricity & Magnetism, Optics, or Modern and run through that experiment several times, virtually, changing the initial conditions and recording the outcomes of each run.

Equipment

Equipment Needed

Computer with Internet access (the instructor will decide whether to use the website given below, another website, or a CD-ROM simulation program),

-OR -

Physics Computer Simulation Program found on the laboratory computers (Instructor will give specifics)

Procedure

There is a large number of simulation packages available, from CD's and DVD's in the Physics Learning Center (NSCI 324), to websites that offer applets and downloads that demonstrate various principles of physics. For this experiment, we will choose one such simulation within the areas mentioned above from the following website:

<http://webphysics.ph.msstate.edu/jc/library/>

Go to this website, and click on one of the choices in the list. The list includes simulations in the following areas:

- 10.3 Archimedes' Principle
- 12.4 The Ideal Gas Law
- 12.5 The Kinetic Theory of Gases
- 13.3 The Carnot Cycle and the Efficiency of Engines
- 13.PP Physics in Practice: Gasoline Engines
- 14.1 Hooke's Law
- 14.6 Damped Harmonic Motion

- 15.1 Pulses on a Rope
- 15.4 Sound Waves
- 15.5 Measuring Sound Levels
- 15.6 The Doppler Effect
- 15.9 Standing Waves on a String
- 15.11 Beats
- 16.5 Superposition of Electric Fields
- 18.2 Electric Resistance and Ohm's Law
- 18.7 Applications of Kirchhoff's Rules
- 19.4 Magnetic Forces on Moving Charged Particles
- 20.3 Generators and Motors
- 20.9 Electromagnetic Waves
- 21.2 The RC Circuit
- 21.5 R-L-C Series Circuit
- 22.1 Models of Light: Rays and Waves
- 22.2 Reflection and Refraction
- 22.5 Thin Lenses
- 22.6 Locating Images by Ray Tracing.
- 22.7 The Thin-Lens Equation
- 24.2 Reflection and Refraction of Light Waves
- 24.3 Interference of Light
- 24.7 Resolution and the Rayleigh Criterion
- 24.8 Dispersion
- 25.1 Principle of Relativity
- 25.5 Time Dilation
- 26.5 Crystals and X-Ray Diffraction
- 27.1 Spectroscopy
- 27.4 The Photoelectric Effect
- 27.6 Successes of the Bohr Theory
- 28.8 Tunneling or Barrier Penetration
- 30.7 Color by Addition and Subtraction
- 31.8 The pn-junction

Select one or more simulations from this list and do them, varying the parameters and seeing how this varying affects the outcome of the experiment. You could either choose an experiment that will not be done this semester, or an experiment that has been done already. In the latter case, the initial conditions of the experiment can be modified to see how the results differ from that experienced in the classroom.

Alternate Procedure

Your instructor may decide to use the simulation programs included in the Physics Learning Center instead of going online to the above site. Internet problems may result in this as well. Follow the directions given by the instructor and the simulation program(s) being used.

Index of Refraction of Laser Light

Purpose

The purpose of this laboratory exercise is to study the nature of refraction of light with a laser.

Background and Theory

When a light beam falls on a surface, both reflection from the surface and refraction into the substance occurs. Refraction is the bending of light as it passes from one substance to another. As light passes from a less dense to a more dense material it bends towards the perpendicular to the plane of the surface of the material. Conversely, light entering a less dense material will bend away from the perpendicular to the plane of the surface. The amount of bending which occurs depends both on the wavelength of the light and the type of material through which the light is propagating. A property of the material related to the amount of refractive bending is called the index of refraction of the material. The index of refraction of a material is usually quoted with respect to vacuum, where the vacuum is defined to have an index of refraction of one. The index of refraction of air is almost that of a vacuum, so light traveling in air can be considered to be in a vacuum. (This is a good approximation for three significant figure accuracy.)

The defining equation for the index of refraction between any two materials is:

$$n_{\alpha} \sin \alpha = n_{\beta} \sin \beta$$

where α is the bending angle with respect to the external medium, β is the bending angle with respect to the internal medium, n_{α} is the index of refraction of the external medium, and n_{β} is the index of refraction of the internal medium.

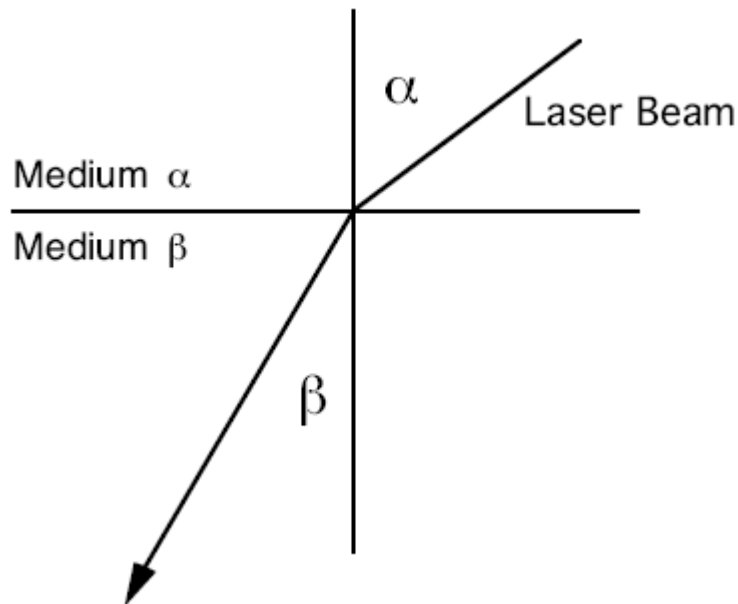

For the case where the medium α is air, then n_{α} is nearly one and we can rearrange the

above equation to solve for the index of refraction of the material as:

$$n = \frac{\sin \alpha}{\sin \beta} \quad (\text{where } n \equiv n_{\beta})$$

We will use a laser beam as a source for the light ray (a laser generates a coherent, monochromatic light beam) with which to find the index of refraction of a slab of transparent material. This value for the index of refraction is valid only for photons that have the same wavelength as those from the laser.

Equipment

Equipment Needed	Qty.
Laser	1
Glass block	1
Protractor or circular optics table	1

Procedure

1. Use the materials listed and the above equation to determine the index of refraction of the glass block. A good procedure is to lay the block flat on a piece of paper and shine the laser light through the edge at a sufficiently large angle. Make a mark on the paper where the light enters and leaves the block. Construct perpendicular lines to the face of the edge to be used for measuring the appropriate angles.
2. What are the units of the index of refraction?
3. What are some sources of error?
4. Do you have enough information to determine the type of material the block is made of? Why?
5. Round off your final answer correctly with respect to the amount of error.
6. Write up your report in the usual manner, remembering to answer all questions.

Bonus 1: Calculate the value of the speed of light inside the object used for refraction.

Bonus 2: Given that the wavelength of the helium-neon laser light is 632.8 nm, what material is the object used for refraction made of?

Concave and Convex Lenses

(Adapted from: Jerry Wilson, *Physics Laboratory Experiments*, 4th Ed., pp. 471-475, © 1994 Houghton Mifflin Company)

Purpose

The purpose of this experiment is to investigate the optical properties of convex and concave lenses.

Background and Theory

Mirrors and lenses are familiar objects that we use on a daily basis. The most commonly used mirror is what is called a plane mirror, which is used for cosmetic applications. Spherical mirrors have many common applications, such as security monitoring of store aisles and merchandise, and concave spherical mirrors are used as flashlight reflectors. Mirrors reflect light, while lenses transmit light. Spherical lenses are used to converge and focus light (convex spherical lenses) and to diverge light (concave spherical lenses).

This experiment will focus on spherical lenses of two types—convex and concave. Convex lenses are sometimes called converging lenses because rays parallel to the principle axis converge at the focal point. A concave lens is called a diverging lens because rays parallel to the perpendicular axis appear to diverge from the focal point.

The characteristics of the images formed by such lenses can be determined either graphically or analytically. In the former method a ray diagram is made, illustrating the paths of several light rays through the lens that enter the lens parallel to the principal axis. The ray is refracted in such a way that it goes through the focal point on transmission through the lens. In the case of a concave lens, the ray appears to have passed through the focal point on the object side of the lens.

If the image is formed on the side of the lens opposite the object, it is real and can be observed on a screen. However, if the image is on the same side of the lens as the object, it is a virtual image and cannot be seen on the screen. Analytically, the thin-lens equation and magnification factor are used with the sign convention similar to that in the following table. These equations apply only to thin lenses. The focal length of a lens is given by the lensmaker's equation:

$$\frac{1}{f} = (n - 1) \left(\frac{1}{R_1} + \frac{1}{R_2} \right)$$

where n is the index of refraction for the lens material and the R 's are taken as positive for convex surfaces. Lenses used in the laboratory are made from glass, which has an n between 1.5 and 1.7. As an example, for glass with $n = 1.5$ and symmetrical converging lenses, ($R_1 = R$ and $R_2 = R$), the equation yields $f = R$ (for f to be equal to $R/2$ for a symmetrical lens requires $n = 2$, which is greater than the index of refraction of glass).

The focal length of a lens depends on the R -values in general, which can be different, as well as n .

Quantity	Conditions	Sign
Focal Length, f	Convex Lens	+
	Concave Lens	-
Object distance, d_o	Usually (always in this experiment), although there are some cases of lens combinations where d_o may be negative when an image is used as an object.	+
Image distance, d_i	Image real	+
	Image virtual	-
Magnification, M	Image upright	+
	Image inverted	-

Equipment

Equipment Needed	Qty.
Concave and Convex Lenses (one of each)	1
Convex Lens (focal length longer than 1 st convex lens)	1
Meter stick optical bench (white cardboard can serve as the screen) or precision (PASCO) bench with lens holder and white screen	1
Light Source: candle and candleholder, or electric light source with object arrow.	1

Procedure

Convex Lenses

1. Sketch a ray diagram for a convex lens with the object at its focal point. The image is formed at infinity.
2. Using the lens equation, determine the image characteristics for an object at infinity.
3. Experimentally determine the focal length of the lens. (The lens may be placed in a lens holder and mounted on a meter stick.)
4. Solve cases 1 to 4.

Case 1: $d_o > R$

- a. Sketch a ray diagram for an object at a distance slightly beyond R (i.e., $d_o > R$) and note the image characteristics.
- b. Set this situation up on the optical bench, with the object placed several centimeters beyond the radius of curvature (known from f determination with $R=2f$). Measure the object distance d_o , and record it. It is usually convenient the lens manually and adjust the object distance by moving the lens rather than the object light source. Move the screen along the side of the optical bench until an image is observed on the screen. This is best observed in a darkened room. The lens may have to be turned slightly to direct the rays toward the screen.
- c. Estimate the magnification factor M and measure and record the image distance d_i .
- d. Using the lens equation, compute the image distance and the magnification factor.
- e. Compare the computed value of d_i with the experimental value by computing the percent difference

Case 2: $d_o = R$. Repeat the procedure for this case.

Case 3: $f < d_o < R$. Repeat the procedure for this case.

Case 4: $d_o < f$. Repeat the procedure for this case.

It is initially instructive to move the lens continuously toward the object light source (decreasing d_o) from a $d_o > 2f$ and to observe the image on the screen, which also must be moved continuously to obtain a sharp image. In particular, notice the change in the size of the image as d_o approaches f .

Concave Lens

5. Sketch ray diagrams for objects at (1) $d_o > R$, (2) $f < d_o < R$, and (3) $d_o < f$, and draw conclusions about the characteristics of the image of a convex lens. Experimentally verify that the image of a convex lens is virtual (i.e., try to locate the image on the screen).
6. It is possible to determine the focal length of a concave lens experimentally by placing it in contact, the lens combination has a focal length f_c given by

$$\frac{1}{f_c} = \frac{1}{f_1} + \frac{1}{f_2}$$

Place the concave lens in contact with the convex lens (convex surface to concave surface) in a lens holder and determine the focal length of the lens combination f_c by finding the image of a distant object. Record the results in the Laboratory Report.

Using the equation $\frac{1}{f_c} = \frac{1}{f_1} + \frac{1}{f_2}$ with the focal length of the convex lens determined

in procedure **1**, compute the focal length of the concave lens.

Laser with Diffraction Grating

(Adapted from Halliday / Resnick / Walker *Probeware Lab Manual*, 6th Ed., pp. 182-183,
© 2003 John Wiley & Sons, Inc.)

Purpose

The purpose of this experiment is to investigate the optical properties diffraction gratings using a laser.

Safety Note

Do not stare into the aperture (opening where the light comes out) of a laser at any time! Exposure to the laser light could result in permanent eye damage.

Background and Theory

When monochromatic light from a distant source such as a laser passes through a narrow slit then falls on a viewing screen, the light produces on the screen a diffraction pattern. This pattern consists of a broad and intense (very bright) central maximum and a number of narrower and less intense maxima (secondary maxima). Minima lie between the maxima. A Light Sensor measures the intensity of this pattern; the Rotary Motion Sensor mounted on the Linear Translator measures the relative positions of the maxima in the pattern.

The diffraction pattern for a single slit is similar to the pattern created by a double slit, but the central maxima is measurably brighter than the maxima on either side. Analysis of wave diagrams for light of wavelength λ passing through a single slit with width “ a ” gives the following general equation: $a\sin\theta = m\lambda$ where θ is the angle of the first dark fringe on either side of the central maxima. The dark fringes can be located with the general equation for $m = 1, 2, 3, \dots$, relating wavelength (λ), the number of fringes (m), and the slit width (a).

Analysis of wave diagrams for light of wavelength λ passing through a double slit with slit spacing “ d ” gives the following formula: $d\sin\theta = m\lambda$. The bright fringes can be located with this equation.

Equipment

Equipment Needed (Without Computer Assistance)	Qty.
Optical Bench	1
Laser	1
Transmission gratings, 200, 300, 600, 13,400 lines/mm	1 each

Equipment Needed (With Computer Assistance)	Qty.
Optics Bench	1
Aperture Bracket	1
Diode Laser	1
Light Sensor	1

Linear Translator	1
Slit Accessory	1
Rotary Motion Apparatus	1

Procedure

Without the Assistance of the Computer Interface Equipment

1. Set up the apparatus as instructed, with the laser at one end, the screen (or, recommended, a blank white or light colored wall) at the other end, and a plastic rectangular diffraction grating mounted between the two.
2. Measure and record: the distance d_1 of the aperture opening of the laser on the ruler of the optics bench; the distance d_2 of the transmission grating, the distance, d_3 of the wall. Take the absolute value of $d_1 - d_2$ to get the grating distance from the laser. Take the distance $d_3 - d_2$ to get the distance d from the grating to the wall. You'll need this to get the θ later in the experiment.
3. Once the setup has been measured, don't move any components. Activate the laser and shine it through the 200 lines / mm transmission grating. Identify the $m = 0$ spot and measure the distance from this spot to each of the spots on one or the other side of this center spot (D_1, D_2, D_3, \dots). Find the grating constant d by the following relation: $d = 1/N$, where N is the number of lines per unit length.
4. Repeat with the other transmission gratings. For each distance, D , measured, find θ through the relation $\theta_n = \arctan(D_n/d)$, $n = 1, 2, 3, \dots$ you should measure the distances to at least three secondary maxima, if possible.
5. For each case you have measured, find λ . This can be found by changing the two-slit equation around slightly (solve for λ). Don't forget to include the correct m in the equation.
6. Find the mean of all of the λ 's you calculated, as well as the standard deviation (you can use your calculator if you wish...) and the % difference of the average calculated wavelength (λ_{calc}) versus the wavelength given by the manufacturer (λ_{given}) of the laser:

$$\%diff = \left| \frac{(\lambda_{\text{calc}} - \lambda_{\text{given}})}{\lambda_{\text{given}}} \right| \times 100\%$$

With the Assistance of the Computer Interface Equipment

(NOTE: Steps 1 through 4 may have already been done for you; if the experiment is set up already, proceed to Step 5)

1. Put the Linear Translator onto the Optics Bench so the rack is perpendicular to the long axis of the Optics Bench. Mount the rotary Motion Sensor onto the Rack of the Linear Translator as described in the Introduction. Remove the "O" ring and thumbscrew from the Rotary Motion Sensor pulley so they will not interfere with the Aperture Bracket.
2. Mount the Light Sensor onto the Aperture Bracket post into the threaded hole on the bottom of the Light Sensor as shown.
3. Put the post into the rod clamp on the end of the Rotary Motion Sensor. Lower the Aperture Bracket until it rests on the top of the Rotary Motion Sensor. Tighten the Rod Clamp thumbscrew to hold the aperture Bracket and Light Sensor in place.

4. Mount the Diode Laser and a Slit Accessory at the other end of the Optics Bench. For example, put the MULTIPLE SLIT SET into the Slit Accessory holder.
5. If an electronic workbook is available for this lab, and if directed to do so by the instructor, refer to the workbook for the remainder of the experiment. Otherwise, continue with this procedure at step 6.
6. Plug in the power supply for the Diode Laser. Turn on the laser to adjust the beam if necessary.
7. Rotate the SLIT SET disk on the Slit Accessory until a slit pattern is in line with the laser beam. Use the adjustment screws on the back of the Diode Laser to adjust the beam if necessary.
8. Rotate the pulley on the top of the Rotary Motion Sensor to move it along the rack on the Linear Translator. Move the Rotary Motion/ Light Sensor until the white screen on the front of the Aperture Bracket shows the diffraction pattern.
9. Examine the diffraction pattern on the white screen. If the pattern is not horizontal, loosen the thumbscrew on the Slit Accessory. Slowly rotate the Slit Accessory until the laser beam is centered on the slit pattern you want and the diffraction pattern is horizontal on the white screen on the Aperture Bracket. Tighten the thumbscrew on the Slit Accessory to hold it in place.
10. Rotate the Aperture Disk on the front of the Aperture Bracket until the narrowest slit opening is in front of the light Sensor opening. This reduces the amount of ambient light that can enter the Light Sensor while the Light Sensor is between maxima of the diffraction pattern.
11. Move the Rotary Motion Sensor/Light Sensor along the rack on the Linear Translator until the center of the diffraction pattern is aligned with the center of the narrow slit on the Aperture Disk of the Aperture Bracket. Loosen the Rotary Motion Sensor up or down if necessary.

Data Recording

Refer to *Physics Labs with Computers*, Volume 2, (PASCO Model CI-7010, copies will be made available to the class), the electronic workbook that accompanies this lab exercise, or other relevant sources for information about data recording using a ScienceWorkshop interface.