



A New Family of PR Two Channel Filter Banks

Jian-ao Lian

Department of Mathematics
Prairie View A&M University
Prairie View, TX 77446-0519 USA
e-mail: JiLian@pvamu.edu

Received August 22, 2007; accepted November 4, 2007

Abstract

A new family of multidimensional dimensional (MD) perfect reconstruction (PR) two channel filter banks with finite impulse response (FIR) filters induced from systems of biorthogonal MD scaling functions and wavelets are introduced. One of the advantages of this construction is that the biorthogonal scaling functions and wavelets are easy to establish due to the interpolatory property of the scaling functions to start with. The other advantage is that all filters can be centrosymmetric or bi-linear phase. Examples of two dimensional (2D) bi-linear phase PR two-channel FIR filter banks will be demonstrated.

Key Words: Biorthogonality; Filter banks; Interpolatory; Perfect reconstruction; Wavelets

MSC 2000: 39B22; 41A58; 41A63; 42B10

1. Introduction

IT is interesting to observe the overlap nowadays between the study of the multidimensional (MD) perfect reconstruction (PR) quadrature mirror filter (QMF) filter banks and the study of multivariate scaling functions and wavelets. Tensor products of the classical one dimensional Daubechies orthonormal (o.n.) scaling functions and wavelets in Daubechies [5] have numerous successfully applications, with those applications in signal and image processing in particular. This natural extension from 1D to MD, plus its easy implementation and the cost-effectiveness, makes the tensor product wavelets the benchmark for signal and image processing. However, on one hand, filter banks induced from *nonseparable* scaling functions and wavelets are expected

in order to better handle other issues such as the directional texture of an image. On the other hand, to construct a 2D filter bank corresponding to a *nonseparable orthonormal* multivariate scaling function and wavelet is not an easy job. Biorthogonality becomes de facto the standards for JPEG2000 (<http://www.jpeg.org/jpeg2000/>).

For a given scaling function with a sampling matrix A , the number of mother wavelets is determined by the value of $|\det A| - 1$. Henceforward, to reduce the number of wavelet generators, it is natural to consider sampling matrices with small determinants in modulus such as two or three. Though there are small variations for quincunx sampling matrix, we are, in this paper, particularly interested in the 2D interpolatory biorthogonal scaling functions and wavelets with the following *symmetric* quincunx sampling matrix

$$A = \begin{bmatrix} 1 & 1 \\ 1 & -1 \end{bmatrix}, \quad (1)$$

which satisfies both $|\det(A)| = 2$ and $A^2 = 2I_2$, with I_2 the identity matrix of order 2. Hence, there will be only one 2D mother wavelet corresponding to such a 2D scaling function (or father wavelet).

There were some studies in the literature for the sampling matrix $2I_2$, particularly with box spline prewavelets, for instance, Belogay & Wang [1], Chui, et al. [3], Riemenschneider & Shen [14] & [15]. For some studies on quincunx sampling, see Cohen & Daubechies [4], Han & Jia [6], He & Lai [7], Lian [10], [11], & [12], Vetterli & Kovačević [16], and the references therein.

Here is the organization of this paper. Some necessary but lengthy notations and definitions will be given in Section 2. Our main results will be presented in Section 3. Three examples of the family of FIR bi-linear PR QMF filter banks will be constructed in Section 4 while Section 5 contains the conclusion.

2. Notations

For simplicity and unless otherwise indicated, we will, in the sequel, fix A as the quincunx sampling matrix in (1), although all material we present here applies to any sampling matrix A that has integer entries, satisfies $|\det(A)| = 2$, and all its eigenvalues are greater than 1 in modulus. The procedure can also be extended to s -D.

Let ϕ be a 2D scaling function with the quincunx sampling matrix A , and ψ a 2D wavelet corresponding to ϕ . Let $\tilde{\phi}$ be a 2D scaling function, again, with quincunx sampling matrix A , and is biorthogonal to ϕ . Let $\tilde{\psi}$ be a 2D wavelet orthogonal to $\tilde{\phi}$ (and biorthogonal to ψ). With the inner product of two functions $f, g \in L^2(\mathbb{R}^s)$ and the Fourier transform \hat{f} of f defined by

$$\langle f, g \rangle = \int_{\mathbb{R}^s} f(\mathbf{x}) \overline{g(\mathbf{x})} d\mathbf{x}, \quad (2)$$

and

$$\hat{f}(\omega) = \int_{\mathbb{R}^s} f(\mathbf{x}) e^{-j\omega \cdot \mathbf{x}} d\mathbf{x}, \quad (3)$$

respectively, the quadruplet, or the perfect reconstruction system with respect to $\{\phi, \psi, \tilde{\phi}, \tilde{\psi}\}$, satisfies

$$M(\mathbf{z}) \tilde{M}(\mathbf{z})^* = I_2, \quad |z_1| = |z_2| = 1, \quad (4)$$

with

$$M(\mathbf{z}) = \begin{bmatrix} P(\mathbf{z}) & P(-\mathbf{z}) \\ Q(\mathbf{z}) & Q(-\mathbf{z}) \end{bmatrix},$$

$$\tilde{M}(\mathbf{z}) = \begin{bmatrix} \tilde{P}(\mathbf{z}) & \tilde{P}(-\mathbf{z}) \\ \tilde{Q}(\mathbf{z}) & \tilde{Q}(-\mathbf{z}) \end{bmatrix},$$

where $*$ denotes the complex conjugation, and P, Q, \tilde{P} , and \tilde{Q} are the two-scale symbols of $\phi, \psi, \tilde{\phi}$, and $\tilde{\psi}$, respectively, namely,

$$\begin{aligned} \hat{\phi}(\omega) &= P(e^{-jA^{-T}\omega}) \hat{\phi}(A^{-T}\omega), \\ \hat{\psi}(\omega) &= Q(e^{-jA^{-T}\omega}) \hat{\phi}(A^{-T}\omega), \\ \hat{\tilde{\phi}}(\omega) &= \tilde{P}(e^{-jA^{-T}\omega}) \hat{\tilde{\phi}}(A^{-T}\omega), \\ \hat{\tilde{\psi}}(\omega) &= \tilde{Q}(e^{-jA^{-T}\omega}) \hat{\tilde{\phi}}(A^{-T}\omega), \end{aligned}$$

with

$$P(\mathbf{z}) = \frac{1}{2} \sum_{\mathbf{k} \in \mathbb{Z}^2} p[\mathbf{k}] \mathbf{z}^{\mathbf{k}}, \quad Q(\mathbf{z}) = \frac{1}{2} \sum_{\mathbf{k} \in \mathbb{Z}^2} q[\mathbf{k}] \mathbf{z}^{\mathbf{k}},$$

$$\tilde{P}(\mathbf{z}) = \frac{1}{2} \sum_{\mathbf{k} \in \mathbb{Z}^2} \tilde{p}[\mathbf{k}] \mathbf{z}^{\mathbf{k}}, \quad \tilde{Q}(\mathbf{z}) = \frac{1}{2} \sum_{\mathbf{k} \in \mathbb{Z}^2} \tilde{q}[\mathbf{k}] \mathbf{z}^{\mathbf{k}}.$$

Here, for $\mathbf{k} = [k_1, k_2]^T \in \mathbb{Z}^2$ and $\mathbf{z} = [z_1, z_2]^T$, $\mathbf{z}^{\mathbf{k}}$ is defined by $\mathbf{z}^{\mathbf{k}} := z_1^{k_1} z_2^{k_2}$. Moreover, as soon as P and \tilde{P} are determined, Q and \tilde{Q} can be easily obtained from

$$Q(\mathbf{z}) = z_1 \tilde{P}(-\mathbf{z})^*, \quad \tilde{Q}(\mathbf{z}) = z_1 P(-\mathbf{z})^*. \quad (5)$$

The QMF property of $\{p[\mathbf{k}]\}$ and $\{\tilde{p}[\mathbf{k}]\}$ are reflected in one of the identities in (4), namely,

$$P(\mathbf{z}) \tilde{P}(\mathbf{z})^* + P(-\mathbf{z}) \tilde{P}(-\mathbf{z})^* = 1, \quad |z_1| = |z_2| = 1, \quad (6)$$

while, from (5), the FIR PR property follows due to the fact that $\det M(\mathbf{z}) = -z_1$.

In summary, a PR two channel biorthogonal filter bank with quincunx sampling matrix is illustrated in Fig. 1, where

$$y_0[\mathbf{k}] = (x * p_{\downarrow A})[\mathbf{k}] = \sum_{\mathbf{i} \in \mathbb{Z}^2} x[\mathbf{i}] p[A\mathbf{k} - \mathbf{i}],$$

$$y_1[\mathbf{k}] = (x * q_{\downarrow A})[\mathbf{k}] = \sum_{\mathbf{i} \in \mathbb{Z}^2} x[\mathbf{i}] q[A\mathbf{k} - \mathbf{i}],$$

$$\hat{x}[\mathbf{k}] = \sum_{\mathbf{i} \in \mathbb{Z}^2} y_0[\mathbf{i}] \tilde{p}[A\mathbf{i} - \mathbf{k}] + \sum_{\mathbf{i} \in \mathbb{Z}^2} y_1[\mathbf{i}] \tilde{q}[A\mathbf{i} - \mathbf{k}],$$

$p_{\downarrow A}$ denotes downsampling of p by A , meaning $p_{\downarrow A}[\mathbf{k}] = p[A\mathbf{k}]$, and, as usual, $*$ stands for convolution.

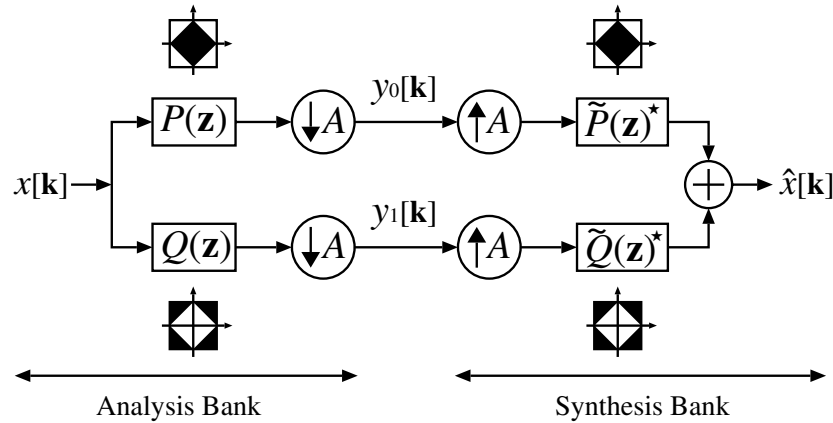

Fig. 1. An illustration for a PR QMF induced from a system of 2D quincunx scaling function ϕ and wavelet ψ and their biorthogonal scaling function $\tilde{\phi}$ and wavelet $\tilde{\psi}$.

The vanishing moments of a wavelet ψ are determined by the polynomial preservation order of its corresponding scaling function ϕ . For FIR filters, the latter is equivalent to the sum rule order m of ϕ 's two-scale symbol $P(\mathbf{z})$, denoted by $P \in \mathbb{SR}_m$. More precisely, $P \in \mathbb{SR}_m$ is equivalent to either $\{p[\mathbf{k}]\}_{\mathbf{k} \in \mathbb{Z}^2}$ satisfies

$$\sum_{\mathbf{k} \in \mathbb{Z}^2} p[A\mathbf{k}] = \sum_{\mathbf{k} \in \mathbb{Z}^2} p \left[A\mathbf{k} + \begin{bmatrix} 1 \\ 0 \end{bmatrix} \right] = 1,$$

$$\sum_{\mathbf{k} \in \mathbb{Z}^2} (A\mathbf{k})^\alpha p[A\mathbf{k}] = \sum_{\mathbf{k} \in \mathbb{Z}^2} \left(A\mathbf{k} + \begin{bmatrix} 1 \\ 0 \end{bmatrix} \right)^\alpha p \left[A\mathbf{k} + \begin{bmatrix} 1 \\ 0 \end{bmatrix} \right],$$

for $1 \leq |\alpha| \leq m - 1$, $\alpha \in \mathbb{Z}_+^2$, or P having the form

$$P(\mathbf{1}) = 1, \quad P(\mathbf{z}) = \mathbf{z}^\beta \sum_{\alpha \in \mathbb{Z}_+, |\alpha| \geq m} s_\alpha \left(\frac{\mathbf{1} + \mathbf{z}}{2} \right)^\alpha, \tag{7}$$

for some $\beta \in \mathbb{Z}^2$, where $\mathbf{1} = [1 \ 1]^\top$ and $|\alpha| = \alpha_1 + \alpha_2$ for $\alpha = [\alpha_1 \ \alpha_2]^\top$. For more equivalent conditions on \mathbb{SR}_m , refer, e.g., Chui & Jiang [2], Jiang [8], Lian [11] & [12].

We end this section by pointing out that we will use the Sobolev exponent with respect to ϕ , denoted by $\nu(\phi)$, to describe the smoothness of a scaling function ϕ , namely,

$$\nu(\phi) = \sup \left\{ \nu : \phi_\ell \in \mathbb{W}^\nu(\mathbb{R}^2), \ell = 1, \dots, s \right\},$$

$$\mathbb{W}^\nu(\mathbb{R}^2) = \left\{ f : \int_{\mathbb{R}^2} (1 + |\omega|^2)^\nu |\hat{f}(\omega)|^2 d\omega < \infty \right\}.$$

3. Main Results

A 2D scaling function ϕ is interpolatory if it satisfies

$$\phi(\mathbf{k}) = \delta_{\mathbf{k},0}, \quad \mathbf{k} \in \mathbb{Z}^2. \tag{8}$$

Similar to the 1D setting, (8) leads to

$$P(\mathbf{z}) + P(-\mathbf{z}) = 1, \quad |z_1| = |z_2| = 1. \quad (9)$$

By the polyphase expression of P , namely,

$$P(\mathbf{z}) = \frac{1}{2} \sum_{\mathbf{k} \in \mathbb{Z}^2} p[A\mathbf{k}] \mathbf{z}^{A\mathbf{k}} + \frac{1}{2} z_1 \sum_{\mathbf{k} \in \mathbb{Z}^2} p[A\mathbf{k} + [1 \ 0]^\top] \mathbf{z}^{A\mathbf{k}},$$

the identity (9) is equivalent to

$$P(\mathbf{z}) = \frac{1}{2} \left(1 + \sum_{\mathbf{k} \in \mathbb{Z}^2, |\mathbf{k}|=\text{odd}} p[\mathbf{k}] \mathbf{z}^{\mathbf{k}} \right). \quad (10)$$

A Laurent polynomial is said to be odd if it consists of terms with odd degrees only. We have the following.

Theorem 1. Let P be a (Laurent) polynomial satisfying (9). Then a (Laurent) polynomial \tilde{P} satisfying (6) is explicitly given by

$$\tilde{P}(\mathbf{z}) = 1 + S(\mathbf{z}) P(-\mathbf{z})^*, \quad (11)$$

where S is an odd (Laurent) polynomial. In particular, \tilde{P} that provides exactly the same sum rule order as that of P is explicitly given by

$$\tilde{P}(\mathbf{z}) = (2P(-\mathbf{z}) + 1) P(\mathbf{z}). \quad (12)$$

Proof. It is straightforward from (11) that

$$\begin{aligned} P(\mathbf{z}) \tilde{P}(\mathbf{z})^* + P(-\mathbf{z}) \tilde{P}(-\mathbf{z})^* \\ = P(\mathbf{z}) + P(-\mathbf{z}) + P(\mathbf{z}) P(-\mathbf{z}) (S(\mathbf{z})^* + S(-\mathbf{z})^*). \end{aligned}$$

Then (6) follows from both (9) and the oddness of S . Similarly, when \tilde{P} is given by (12), we have

$$\begin{aligned} P(\mathbf{z}) \tilde{P}(\mathbf{z})^* &= (P(\mathbf{z}))^2 (2P(-\mathbf{z}) + 1) \\ &= 2(P(\mathbf{z}))^2 P(-\mathbf{z}) + (P(\mathbf{z}))^2. \end{aligned}$$

Hence,

$$\begin{aligned} P(\mathbf{z}) \tilde{P}(\mathbf{z})^* + P(-\mathbf{z}) \tilde{P}(-\mathbf{z})^* \\ = 2P(\mathbf{z}) P(-\mathbf{z}) (P(\mathbf{z}) + P(-\mathbf{z})) + (P(\mathbf{z}))^2 + (P(-\mathbf{z}))^2 \\ = (P(\mathbf{z}) + P(-\mathbf{z}))^2 = 1. \end{aligned}$$

That \tilde{P} has the same sum rule order as that of P follows immediately by rewriting \tilde{P} into $\tilde{P}(\mathbf{z}) = (3 - 2P(\mathbf{z}))P(\mathbf{z}) = 3P(\mathbf{z}) - 2(P(\mathbf{z}))^2$. \square

It is worthwhile to point out that, first, this explicit formulation of \tilde{P} by (11) dramatically simplifies the construction of a PR QMF filter bank. Certainly, for a given P , the family of \tilde{P} can be determined from (11) by requiring various values m of $\mathbb{S}\mathbb{R}_m$. Secondly, the Sobolev exponent of the scaling function $\tilde{\phi}$ determined from two-scale symbol \tilde{P} in (12) is usually small.

So, instead of using (12), we always go a little deeper by using (11) to get a \tilde{P} that has sum rule order higher than that of P itself.

4. FIR Bi-Linear Phase PR QMF Filter Banks

It is easy to check that $P(\mathbf{z}) = 1/2 + (z_1 + z_2)/4 \in \mathbb{SR}_1$, one of the simplest two-scale symbols of a quincunx interpolatory scaling function. By applying the *Matlab* routines in Jiang [9], the scaling function $\phi \in \mathbb{W}^{0.7356}$. However, the lowpass filter $\begin{bmatrix} 1/2 & 0 \\ 1 & 1/2 \end{bmatrix}$ is not linear.

A 2D filter $H(\omega_1, \omega_2)$ is said to be bi-linear phase (cf., e.g., Lian [11]) if both $H(\omega_1, \omega_2)$ and $H(\omega_2, \omega_1)$ have linear phase. To construct 2D FIR bi-linear phase PR QMF filter banks, we start off with the construction of 2D quincunx interpolatory scaling functions that are symmetric about the origin. To this end, the “center” of the FIR lowpass filter $\{p[\mathbf{k}]\}$ will be fixed at the origin. If we view $(p[\mathbf{k}])$ as a 2D square matrix, it has odd order and is *centrosymmetric* (cf., e.g., Muir [13]), meaning that it is symmetric with respect to the central entry of the matrix.

Example 1. If S consists of terms with degree 1 in absolute value, it follows from (10) and is also easy to verify by using (7) that

$$(p[\mathbf{k}]) = \frac{1}{4} \begin{bmatrix} 0 & 1 & 0 \\ 1 & 4 & 1 \\ 0 & 1 & 0 \end{bmatrix},$$

with $P \in \mathbb{SR}_2$. Direct construction from (11) and requiring \tilde{P} to have \mathbb{SR}_4 lead to the following bi-linear phase lowpass filter

$$(\tilde{p}[\mathbf{k}]) = \frac{1}{256} \begin{bmatrix} 0 & 0 & 3 & 0 & 3 & 0 & 0 \\ 0 & 6 & -12 & -16 & -12 & 6 & 0 \\ 3 & -12 & -38 & 88 & -38 & -12 & 3 \\ 0 & -16 & 88 & 424 & 88 & -16 & 0 \\ 3 & -12 & -38 & 88 & -38 & -12 & 3 \\ 0 & 6 & -12 & -16 & -12 & 6 & 0 \\ 0 & 0 & 3 & 0 & 3 & 0 & 0 \end{bmatrix}.$$

We also mention here that this bi-linear filter was also established in our earlier work in Lian [11].

Example 2. To get higher sum rule order for P , we include S in (10) with terms of degrees as 1 and 3 in absolute value so that $P \in \mathbb{SR}_4$. This yields

$$(p[\mathbf{k}]) = \frac{1}{32} \begin{bmatrix} 0 & -1 & 0 & -1 & 0 \\ -1 & 0 & 10 & 0 & -1 \\ 0 & 10 & 32 & 10 & 0 \\ -1 & 0 & 10 & 0 & -1 \\ 0 & -1 & 0 & -1 & 0 \end{bmatrix}.$$

Consequently, it follows from (10) and requiring \tilde{P} to have $\mathbb{S}\mathbb{R}_6$ that the “first quadrant” of 32768 $(\tilde{p}[\mathbf{k}])$, which is in $\mathbb{R}^{11 \times 11}$, is given by

$$\begin{bmatrix} 0 & 15 & 0 & 9 & 0 & 0 \\ -172 & 0 & -140 & 0 & 18 & 0 \\ 192 & 741 & 288 & -310 & 0 & 9 \\ -1768 & -2080 & 1856 & 288 & -140 & 0 \\ 11584 & -5316 & -2080 & 741 & 0 & 15 \\ 50536 & 11584 & -1768 & 192 & -172 & 0 \end{bmatrix}.$$

Example 3. Analogous to Example 2, if we allow S to have terms of degrees up to 5 in absolute value and require $P \in \mathbb{S}\mathbb{R}_6$, then $(p[\mathbf{k}])$ is given explicitly by

$$(p[\mathbf{k}]) = \frac{1}{512} \begin{bmatrix} 0 & 3 & 0 & 2 & 0 & 3 & 0 \\ 3 & 0 & -27 & 0 & -27 & 0 & 3 \\ 0 & -27 & 0 & 174 & 0 & -27 & 0 \\ 2 & 0 & 174 & 512 & 174 & 0 & 2 \\ 0 & -27 & 0 & 174 & 0 & -27 & 0 \\ 3 & 0 & -27 & 0 & -27 & 0 & 3 \\ 0 & 3 & 0 & 2 & 0 & 3 & 0 \end{bmatrix}.$$

Moreover, $(\tilde{p}[\mathbf{k}]) \in \mathbb{R}^{15 \times 15}$, with $\tilde{P} \in \mathbb{S}\mathbb{R}_8$, can also be established. Due to the limitation of space here, we omit $(\tilde{p}[\mathbf{k}])$ in this paper.

The Sobolev exponents of all three pairs of ϕ and $\tilde{\phi}$ are included in the following Table 1.

Table 1. Sobolev Exponents of the Three Pairs of ϕ and $\tilde{\phi}$ in Examples 1, 2 and 3

$\mathbb{S}\mathbb{R}_m$ of ϕ	$\nu(\phi)$	$\nu(\tilde{\phi})$	$\mathbb{S}\mathbb{R}_m$ of $\tilde{\phi}$
$m = 2$	1.5776	0.3141	$m = 4$
$m = 4$	2.4479	0.9332	$m = 6$
$m = 6$	3.1543	1.4838	$m = 8$

5. Conclusion

A new family of 2D FIR bi-linear phase PR QMF filter banks induced from systems of biorthogonal 2D quincunx interpolatory and symmetric scaling functions and wavelets was introduced. Not only was the procedure both simple and straightforward but also the corresponding biorthogonal quincunx scaling functions are easy to construct. Some of our future work in this direction will be: (1) construction of framelets for this family of scaling functions; (2) consideration of other sampling matrices; (3) study for similar problems in 3D setting; (4) application of these results to, e.g., signal and image processing and data fitting; and (5) connection to subdivision schemes for rendering and/or surface design.

Acknowledgment

This work was partially supported by ARO under Grant W911NF-05-1-0388.

References

- [1] E. Belogay and Y. Wang, "Arbitrarily smooth orthogonal nonseparable wavelets in \mathbb{R}^2 ," *SIAM Math. Analysis* **30** (1999), 678–697.
- [2] C. K. Chui and Q. T. Jiang, "Multivariate balanced vector-valued refinable functions," in: MODERN DEVELOPMENT IN MULTIVARIATE APPROXIMATION, ISNM 145, V. W. Hausmann, K. Jetter, M. Reimer, and J. Stöckler (eds.), Birkhäuser Verlag, Basel, 2003, 71–102.
- [3] C. K. Chui, J. Stöckler, and J. D. Ward, "Compactly supported box spline wavelets," *Appl. Theory Appl.* **8** (1992), 77–100.
- [4] A. Cohen and I. Daubechies, "Nonseparable bidimensional wavelet bases," *Rev. Mat. Iberoamericana* **9** (1993), 51–137.
- [5] I. Daubechies, "TEN LECTURES ON WAVELETS," CBMS-NSF 61, SIAM, Philadelphia, PA, 1992.
- [6] B. Han and R. Q. Jia, "Quincunx fundamental refinable functions and quincunx biorthogonal wavelets," *Math. Comp.* **71** (2002), 165–196.
- [7] W. J. He and M. J. Lai, "Construction of bivariate compactly supported biorthogonal box spline wavelets with arbitrarily high regularities," *Appl. Comp. Harmonic Analysis*: **6** (1999), 53–74.
- [8] Q. T. Jiang, "Multivariate matrix refinable functions with arbitrary matrix dilation," *Trans. of Amer. Math. Soc.* **351** (1999), 2407–2438.
- [9] Q. T. Jiang (2001, April). "Matlab routines for Sobolev and Hölder smoothness computations of refinable functions." [Online]. Available: <http://www.cs.umsl.edu/~jiang/Jsoftware.htm>.
- [10] J.-A. Lian, "On multivariate multiwavelets," in: GEOMETRIC MODELING AND COMPUTING, M. L. Lucian and M. Neamtu (eds.), Nashboro Press, Brentwood, TN, 2005, 377–386.
- [11] J.-A. Lian, "On bivariate scaling functions and wavelets," in: WAVELETS AND SPLINES: ATHENS 2005, Guanrong Chen and Ming-Jun Lai (eds.), Nashboro Press, Brentwood, TN, 2006, 328–345.
- [12] J.-A. Lian, "Multidimensional PR filter banks with FIR filters," in: PROCEEDINGS OF THE IEEE 2006 INTERNATIONAL CONFERENCE ON COMMUNICATIONS, CIRCUITS AND SYSTEMS (ICCCAS), June 25–28, 2006, Guilin, Guangxi, China, 162–166.
- [13] T. Muir, "A TREATISE ON THE THEORY OF DETERMINANTS," New York, Dover, 1960.
- [14] S. D. Riemenschneider and Z. W. Shen, "Box splines, cardinal series, and wavelets," in: APPROXIMATION THEORY AND FUNCTIONAL ANALYSIS, C. K. Chui (eds.), Academic Press, New York, NY, 1991, 133–149.
- [15] S. D. Riemenschneider and Z. W. Shen, "Wavelets and pre-wavelets in low dimensions," *J. Approx. Theory* **71** (1992), 18–38.
- [16] M. Vetterli and J. Kovačević, "WAVELETS AND SUBBAND CODING," Prentice Hall PTR, Englewood Cliffs, NJ, 1995.