



Effect of Glycocalyx on Red Blood Cell Motion in Capillary Surrounded by Tissue

Rekha Bali, Swati Mishra

Department of Mathematics
Harcourt Butler Technological Institute
Kanpur, India

P. N. Tandon

Res. No. 191-193, Karmcharinagar
Bareilly, INDIA

Received: June 22, 2008; Accepted: March 13, 2009

Abstract

The aim of the paper is to develop a simple model for capillary tissue fluid exchange system to study the effect of glycocalyx layer on the single file flow of red cells. We have considered the channel version of an idealized Krogh capillary-tissue exchange system. The glycocalyx and the tissue are represented as porous layers with different property parametric values. Hydrodynamic Lubrication theory is used to compute the squeezing flow of plasma within the small gap between the cell and the glycocalyx layer symmetrically surrounded by the tissue. The system of non linear partial differential equations has been solved using analytical techniques. The model predicts that decrease in glycocalyx thickness reduces the axial velocity of plasma and the resistance to flow increases in presence of glycocalyx.

Key words: Glycocalyx; Capillary Blood Flow; Pressure; Resistance to Flow; Velocity Profile

MSC (2000) No.: 76Z05, 74F10

1. INTRODUCTION

Microscopic observations identified a thin, negatively charged macromolecular layer adjacent the luminal surface of vascular endothelial surface of the capillary. This layer was named as glycocalyx and was hypothesized to affect the transport properties of the capillary wall. Glycocalyx, a layer of macromolecules bounded or adsorbed to the endothelial surface, may retard plasma motion in a zone adjacent to the capillary wall [Sugihara-Seki & Bingmei (2005)]. Regulation of the exclusion of blood from this relatively thick endothelial region could contribute, not only to control of capillary red blood cell filling the space and oxygen supply to tissue cells, but also to the controlled modulation of transcapillary solute exchange and tissue hydration.

The state of understanding of the single file motion of red blood cells through cylindrical tubes is relatively mature, beginning with the seminal works of Lighthill (1968), Fitzgerald (1969 a, b) and Bernard et al. (1968) and cumulating in the models of Zerda et al. (1977) and Secomb et al. (1986), which are faithful to the constitutive relationships and well characterized the red cell membrane. However, experimental evidence mounting over the past 20 years has begun to cast doubt on the applicability of these models to capillary blood flow in vivo. Several experimental studies during the period suggest that the flow resistance measured in vivo was about twice that from estimates based on measurements in glass tubes [Lipowsky et al. (1978, 1980), Pries et al. (1994)]. Although, several mechanisms were considered, the most likely explanation, as demonstrated convincingly by recent experiments of Pries and Secomb (1997) that the glycocalyx is, primarily responsible for the difference [Klitzman & Duling (1979) and Desjardins and Duling (1990)].

Several theoretical models have recently been presented that are generally consisting with this new concept of microvascular resistance and reduction of capillary tube hematocrit [Damiano (1998), Damiano et al. (1996, 2004), Secomb et al. (1998, 2001) and Wang and Parker (1995), Srivastava (2007)]. These authors assumed binary mixture theory and account for deformability of the red cells as they travel in single file through capillaries of roughly $6\mu m$ diameter. They further assume the existence of a thin lubricating layer adjacent to the capillary wall. These models have not discussed the effect of glycocalyx on flow characteristics of single file flow of red cell in capillaries surrounded by tissue and the fluid movement into and out of the tissue through the glycocalyx layer.

Therefore, our aim is to study the effect of glycocalyx on blood flow in very narrow capillary lined with uniform thickness of porous layer (Glycocalyx) which is surrounded by tissue. In this paper, we have considered the glycocalyx as a porous layer. The tissue is also considered as a porous matrix. Darcy's law of fluid flow is assumed to govern the flow in tissue as well as in glycocalyx. The shape of red blood cell is assumed to be axisymmetric. Lubrication theory is used to compute the flow of plasma around the cell. Single file flow of red blood cell is considered and cell to cell interactions are neglected. We have obtained the results for resistance to plasma flow, pressure, normal and axial component of velocity in very narrow capillary.

2. FORMULATION OF THE PROBLEM

We have considered the channel version (Figure1) of an idealized Krogh capillary tissue cylinder as the geometrical representation of the capillary beds. The interior surface of capillary is lined with a glycocalyx layer, which is assumed as a porous matrix. Red blood cell is assumed axisymmetric. Single file flow of red blood cell is considered. Hydrodynamic lubrication theory is used to describe the motion of plasma around the cell. Gap between the cell and capillary wall is given by

$$h' = h_0 + \beta' x'^2, \quad (1)$$

where β' is the shape parameter. The region is divided into three sub regions

- (i) Fluid Film Region, $d' \leq r' < h'$.
- (ii) Glycocalyx Layer, $0 \leq r' \leq d'$.
- (iii) Tissue region, $-H' \leq r' \leq 0$.

We introduce the following non dimensional scheme:

$$x = \frac{x'}{h_0}, \quad y = \frac{y'}{h_0}, \quad P = \frac{P'}{\rho U_0^2}, \quad u = \frac{u'}{U_0}, \quad v = \frac{v'}{U_0},$$

$$Re = \frac{\rho U_0 h_0}{\mu}, \quad \sigma = \frac{\sigma'}{h_0}, \quad \beta = \beta' h_0, \quad d = \frac{d'}{h_0}, \quad \ell = \frac{\ell'}{h_0}.$$

To write the governing equations for flow in three regions as given below:

(A) Fluid Film Region

In between the red cell and the glycocalyx surface there is a thin lubricating layer of plasma. Therefore, introducing lubrication theory, the governing equations of motion and continuity for two dimensional flow of plasma (considered as Newtonian fluid) may be written as follows:

$$Re \frac{\partial P}{\partial x} = \frac{\partial^2 u}{\partial y^2}, \quad (2)$$

$$\frac{\partial P}{\partial y} = 0, \quad (3)$$

$$\frac{\partial u}{\partial x} + \frac{\partial v}{\partial y} = 0, \quad (4)$$

where u and v are the velocity component along axial and transverse directions and μ is the viscosity of plasma in the capillary. P is the pressure in fluid film region.

(B) In Glycocalyx and Tissue Region

The flow of viscous fluid in porous matrices is governed by Darcy's Law. Therefore axial and normal component of velocity are given as:

$$\bar{u}_i = -\bar{k}_i \text{Re} \frac{\partial \bar{P}_i}{\partial x} \quad \text{and} \quad \bar{v}_i = -\bar{k}_i \text{Re} \frac{\partial \bar{P}_i}{\partial y}, \quad (5)$$

where $\bar{k}_i = \frac{k_i}{h_0^2}$, $i = 1$ stands for the glycocalyx layer and $i = 2$ stands for tissue region. \bar{u}_i and \bar{v}_i are the axial and normal velocities of the fluid in the porous matrix of glycocalyx and tissue.

Pressures in the two porous regions satisfy the Laplace equation. Thus, \bar{P}_1 , the pressure in the glycocalyx layer of thickness d and \bar{P}_2 , is the pressure in the tissue region of thickness H satisfies the Laplace equations:

$$\nabla^2 \bar{P}_i = 0. \quad (6)$$

Boundary and Matching Conditions

$$u = U_0 \quad \text{at} \quad y = h \quad (7a)$$

$$u = -\sigma \frac{\partial u}{\partial y} \quad \text{at} \quad y = d \quad (7b)$$

$$v = 0 \quad \text{at} \quad y = h \quad (7c)$$

$$\frac{\partial \bar{P}_2}{\partial y} = 0 \quad \text{at} \quad y = -H \quad (7d)$$

$$P = P_0 \quad \text{at} \quad x = \pm \ell \quad (7e)$$

$$P = \bar{P}_1 \quad \text{at} \quad y = d \quad (7f)$$

$$k_1 \frac{\partial \bar{P}_1}{\partial y} = \delta_1 k_2 \frac{\partial \bar{P}_2}{\partial y} \quad \text{at} \quad y = 0 \quad (7g)$$

$$\bar{P}_1 = \delta_2 \bar{P}_2 \quad \text{at} \quad y = 0, \quad (7h)$$

where U_0 is the cell velocity, σ is the slip parameter, P_0 is the reference pressure, k_1 and k_2 are the permeability of glycocalyx layer and tissue. δ_1 and δ_2 are the partition coefficients, h_0 is the minimum gap width

$$\begin{aligned}
 x &= \frac{x'}{h_0}; & y &= \frac{y'}{h_0}; & P &= \frac{P'}{\rho U_0^2}; & u &= \frac{u'}{U_0}; & v &= \frac{v'}{U_0}; \\
 Re &= \frac{\rho U_0 h_0}{\mu}; & \sigma &= \frac{\sigma'}{h_0}; & \beta &= \beta' h_0; & d &= \frac{d'}{h_0}; & \ell &= \frac{\ell'}{h_0}.
 \end{aligned} \tag{8}$$

SOLUTION OF THE PROBLEM

Capillary Region

Solving equation of motion and equation of continuity with the help of boundary condition 7(a) and 7(b) we get the solution for velocity distribution in the capillary region as given by

$$u = Re \frac{\partial P}{\partial x} \frac{y^2}{2} + Ay + B, \tag{9}$$

where

$$\begin{aligned}
 A &= \frac{1}{(h - \sigma - d)} + \frac{Re(\sigma d + d^2)}{(h - \sigma - d)} \frac{\partial P}{\partial x}, \\
 B &= \frac{-(\sigma + d)}{(h - \sigma - d)} - Re \frac{\partial P}{\partial x} \left\{ \frac{h^3 - h^2(\sigma + d) + 2hd(\sigma + d)}{2(h - \sigma - d)} \right\}.
 \end{aligned}$$

Porous Region

Pressure in porous tissue and glycocalyx are governed by the Laplace equation

$$\nabla^2 \bar{P}_1 = 0. \tag{10}$$

Thus, \bar{P}_1 , the pressure in the glycocalyx layer of thickness d , satisfies the equation

$$\frac{\partial^2 \bar{P}_1}{\partial x^2} + \frac{\partial^2 \bar{P}_1}{\partial y^2} = 0. \tag{11}$$

Integrating equation (11) with respect to y over the layer thickness d and using boundary condition (7g)

$$\left. \frac{\partial \bar{P}_1}{\partial y} \right|_{y=d} = - \int_0^d \frac{\partial^2 \bar{P}_1}{\partial x^2} dy + \frac{k_2}{k_1} \delta_1 \left. \frac{\partial \bar{P}_2}{\partial y} \right|_{y=0}. \tag{12}$$

Similarly, we integrate the Laplace equation in tissue layer of thickness H and using condition (7d)

$$\left. \frac{\partial \bar{P}_2}{\partial y} \right|_{y=0} = - \int_{-H}^0 \frac{\partial^2 \bar{P}_2}{\partial x^2} dy. \quad (13)$$

From (12) and (13) we get

$$\left. \frac{\partial \bar{P}_1}{\partial y} \right|_{y=d} = - \left(\int_0^d \frac{\partial^2 \bar{P}_1}{\partial x^2} dy + \frac{k_2}{k_1} \delta_1 \int_{-H}^0 \frac{\partial^2 \bar{P}_2}{\partial x^2} dy \right). \quad (14)$$

If the layer thickness d and H are assumed to be small, equation (14) reduces to

$$\left. \frac{\partial \bar{P}_1}{\partial y} \right|_{y=d} = - \left(d + \frac{\delta_1 k_2}{\delta_2 k_1} H \right) \frac{\partial^2 P}{\partial x^2}. \quad (15)$$

Introducing axial velocity in equation of continuity and using the condition at the interface (7f) pressure distribution in capillary region is obtained as

$$P = \left[F_{10} \frac{x^2}{2} - F_{16} \frac{x^4}{8} + F_{17} \frac{x^5}{5} \right] + C_1 \left[-x + F_{17} \frac{x^2}{2} - F_{18} \beta \frac{x^4}{24} \right] + C_2, \quad (16)$$

where

$$C_1 = \left[F_{17} \frac{\ell^4}{5} \right]$$

$$C_2 = P_0 - [L_1 + L_2 + L_3]$$

$$L_1 = \left[F_{19} \frac{\ell^2}{2} - F_{16} \frac{\ell^4}{8} + F_{17} \frac{\ell^5}{5} \right]$$

$$L_2 = \left[F_{17} \frac{\ell^4}{5} \right]$$

$$L_3 = \left[\ell - F_{17} \frac{\ell^2}{3} + F_{18} \beta \frac{\ell^4}{24} \right]$$

$$F_1 = \left[d\delta_2 + \delta_1 \frac{k_2}{k_1} H + \frac{Re}{3} d^4 \left\{ \left(\frac{\sigma}{d} \right)^2 + \left(\frac{\sigma}{d} \right) + 1 \right\} \right]$$

$$F_2 = \left[\frac{2\sigma - 3\sigma^2}{d^2} - \frac{4\sigma - 1}{d} - 1 \right]$$

$$F_3 = \frac{Re\beta x}{F_1} \left[\frac{\sigma}{4d} - \frac{Re}{3} d^3 \left(\frac{2\sigma}{d} + 8 \right) + 13 \right]$$

$$F_4 = Re\beta x \left[\frac{3\sigma}{d} + 17 \right]$$

$$F_5 = Re\beta x \left[\frac{2\sigma}{d} + 8 \right]$$

$$F_6 = \frac{Re d^3}{3} \left(\frac{F_2}{F_1} \right)$$

$$F_7 = \frac{Re d^3}{3F_1} \left\{ \frac{6(d+1)}{d} - d - 3F_2 \right\}$$

$$F_8 = \left(\frac{F_3 + \sigma F_4 + F_5}{d^2} \right)$$

$$F_9 = \left(\frac{2F_3 + \sigma F_4 - F_5}{d^2} \right)$$

$$F_{10} = F_2 + 3F_6 \left(\frac{\sigma}{d^2} + \frac{2}{d} \right) + F_7$$

$$F_{11} = \frac{3F_6}{d^2} (\sigma + 2d)$$

$$F_{12} = \frac{2}{3} F_9 F_{10} + F_8 F_{11}$$

$$F_{13} = \frac{1}{18} \beta F_9 F_{10}$$

$$F_{14} = 2F_7 F_{10}$$

$$F_{16} = 2F_7^2 F_{10}$$

$$F_{17} = F_{12} - \frac{\beta F_9 F_{10}}{3}$$

$$F_{18} = \frac{\beta}{3} (F_9 F_{10} + F_8 F_{11}).$$

Resistance to blood flow is given as

$$R^* = \frac{P_0 - [L_1 + L_2 + L_3]}{Q}, \quad (17)$$

where Q is the volumetric flow rate [Guyton and Hall (1996)].

Normal component of velocity is obtained as

$$v = - \left[\frac{\text{Re}}{6} \frac{\partial^2 P}{\partial x^2} (y^3 - h^3) + \frac{\partial A}{\partial x} \frac{(y^2 - h^2)}{2} + \frac{\partial B}{\partial x} (y - h) \right], \quad (18)$$

where

$$\begin{aligned} \frac{\partial A}{\partial x} &= - \frac{2\beta x}{(a_1 + \beta x^2)^2} + \frac{a_2}{(a_1 + \beta x^2)^2} \left\{ (a_1 + \beta x^2) \frac{\partial^2 P}{\partial x^2} - 2\beta x \frac{\partial P}{\partial x} \right\} \\ \frac{\partial B}{\partial x} &= - \frac{2\beta x a_4}{(a_1 + \beta x^2)^2} - \text{Re} \frac{\partial^2 P}{\partial x^2} \left\{ \frac{h^3 - a_4 h^2 + a_3 h}{2(a_1 + \beta x^2)} \right\} \\ &\quad - \text{Re} \frac{\partial P}{\partial x} \left\{ \frac{6(a_1 + \beta x^2)h^2 + (-2h + h^2)a_4 + a_3(1 + 2h) - h^3}{(a_1 + \beta x^2)^2} \right\} \end{aligned}$$

$$a_1 = (1 - \sigma - d)$$

$$a_2 = \text{Re}(\sigma d + d^2)$$

$$a_3 = 2d(\sigma + d)$$

$$a_4 = (\sigma + d).$$

3. RESULTS AND DISCUSSIONS

The role of glycocalyx has been described here for blood vessels when red cells flow in a single file. Their effects on pressure distribution, resistance to flow, axial velocity and normal component of velocity have been presented through figure 2 to 9 as discussed below. The presence of the glycocalyx reduces the crosssection available for flow of red cells. The additional energy may be dissipated due to narrowing of the lubrication layer.

Figures 2 and 3 depict the variation of pressure distribution and flow resistance for different values of glycocalyx layer thickness d . These figures demonstrate that both, after attaining a maximum value at the origin, decreases sideways symmetrically. This is due to the assumption of geometrical symmetry and reduction of the gap between the cell geometry and the capillary wall.

Figure 4 and Figure 5 present the variation of normal and axial velocities for different values of glycocalyx thickness. Normal velocity as well as axial velocities both decrease with increasing values of the thickness. Both after attaining maximum value at the origin decrease sideways symmetrically and both the results support each other. Similar results have been observed by Secomb and Hsu (1997). This layer slows down the plasma flow due to the movement of the

fluid from the gap into the layer. The axial velocity profiles of the fluid in the lubricating layer in presence of glycocalyx layer at its luminal surface have also been shown through Figure 5. The glycocalyx acts as a transport barrier. Further work is needed to explain the effects of glycocalyx on nutritional transport to the cells of the tissue.

The present model also studies the effect of various shapes of the red blood cell through the variation of parameter β . The effect of red cell shape parameter has been discussed through figures 6 to 9. Axisymmetric shape of red cell is assumed throughout in the model. In general, red blood cell shapes are not axisymmetric but this has little effect on flow behavior.

Pressure distribution and the Resistance to flow have been presented in the Figure 6 and Figure 7. Pressure in fluid film (lubrication layer) increases (Figure 6) and resistance to flow also increases (Figure 7) with increasing values of β . Normal component of the fluid velocity increases at the capillary-tissue interface as β increases. One may also observe that as β increases, the red cell gets elongated and lubrication layer thickness decreases. Without the glycocalyx, the red cell almost fills the gap width. The presence of the glycocalyx leads to longer and narrower red blood cell shapes, and the width of Lubricating layer changes with β .

Figures 8 and 9 represent the variation of normal and axial velocity of plasma in capillary. Results support the observation in Figures 6 and 7 for different values of β .

4. Concluding Remarks

Introducing the concept of lubrication and the forming a wedge in between porous glycocalyx layer and the assumed shapes of red blood cell, this study presents the effects of glycocalyx layer on physiological parameters of the model. The results support the experimental findings of various researchers [Damiano et.al. (1996); Damiano (1998); Secomb et.al. (1998, 2001); Wang and parker (1995)] Decreasing of the fluid flux into the tissue simultaneously decreases the nutritional transport and oxygen supply to the tissue cells. This would form the basis for further study of coupled diffusion in tissue in presence of glycocalyx layer on inner side of the capillary.

Acknowledgement

The authors gratefully acknowledge the suggestions of the reviewers of original manuscript of the paper for better presentation.

REFERENCES

- Barnard, A.C., Lopez, L. & Hellums, J.D. (1968). Basic theory of blood flow in capillaries. *Micro vascular research*, vol.1, pp. 23-24.
- Christafakis, A. et al. (2009) Modelling of two phase incompressible flows in ducts. *AMM*. Vol. 33, issue 3, pp. 1201-1212.
- Damiano, E.R., Duling, B.R., Ley, K. & Skalak, T.C. (1996). Axisymmetric pressure-driven flow of rigid pellets through a cylindrical tube lined with a deformable porous wall layer. *J. Fluid Mech.*, vol. 314, pp. 163-189.
- Damiano, E.R. (1998). Blood flow in micro vessels lined with a poroelastic wall layer. In *Poromechanics* (ed. J.F. Thimus, Y. Abouseiman, A.H.D. Cheng, O. Coussy & E. Detournay), pp. 403-408, Balkema, Rotterdam.
- Damiano, E.R., Long, D.S., El-Khatib, F.H. and Stace, T.M. (2004). On the motion of a sphere in a Stokes flow parallel to a Brinkman half-space. *J. Fluid Mech.*, vol. 500, pp. 75-101.
- Desjardins, C. & Duling, B.P. (1990). Microvessel hematocrit: measurement and implications for capillary oxygen transport. *A.J. Physiol.*, vol. 252, pp. H494-H503.
- Fitzgerald, J.M. (1969a). Mechanics of red cell motion through very narrow capillaries. *Proc. Roy. Soc. Lond. B*. vol. 174, pp. 193-227.
- Fitzgerald, J.M. (1969b). Implication of a theory of erythrocyte motion in narrow capillaries. *J. Appl. Physiol.* Vol. 27, pp. 912-18.
- Klitzman, B. & Duling, B.P. (1979). Microvascular hematocrit and red cell flow in resting and contracting striated muscle. *Am. J. Physiol.*, vol. 237(Heart circ. Physiol. 6): pp. H481-490.
- Lighthill, M.J. (1968). Pressure forcing of tightly fitting pellets along fluid filled elastic tubes. *J. fluid Mech.*, vol. 34, pp. 113-43.
- Lipowsky, H.H., Kovalcheck, S. & Zweifach, B.W. (1978). The distribution of blood rheological parameters in the microvasculature of cat mesentery. *Circ. Res.*, vol. 43, pp. 738-749.
- Lipowsky, H.H., Usami, S. & Chein, S. (1980). In vivo measurements of 'apparent viscosity' and microvessels hematocrit in the mesentery of the cat. *Microvasc.Res.* vol. 19, pp. 297-319.
- Pries, A.R., Secomb, T.W., Gessner, T., Sperandio, M.B., Gross, J.F. & Gaetgens, P. (1994). Resistance to blood flow in microvessels in vivo. *Circ. Res.*, vol. 75, pp. 904-915.
- Pries, A.R. & Secomb, T.W. (1997). Resistance to blood flow in vivo: From poiseuille to the "in vivo viscosity law". *Biorheology*, vol.34, pp.269-373
- Secomb, T.W., Skalak, R. Ozkaya, N. & Gross, J.F. (1986). Flow of axisymmetric red blood cells in narrow capillaries. *J. Fluid Mech.*, vol. 163, pp. 405-423.
- Secomb, T.W., Hsu, R., 1997. Resistance to blood flow in nonuniform capillaries. *Microcirculation*. 4, 421-427.
- Secomb, T.W., Hsu, R. & Pries, A.R. (1998). A model for red blood cell motion in glycocalyx lined capillaries. *Am. J.Physiol. Heart circ. Physiol.*, vol.274, pp. H 1016-H1022.
- Secomb, T.W., Hsu, R. & Pries, A.R. (2001). Motion of red blood cell in a capillary with an endothelial surface layer: effect of flow velocity. *Am. J. Physiol. Heart circ. Physiol.*, vol. 28, pp. H629-H636.
- Srivastava, V.P. (2007). A theoretical model for blood flow in small vessels. *Application and Applied Mathematics* vol.2, no.1, pp. 51-65.
- Sugihara-Seki, M. and Bingmei, M.Fu (2005). Blood flow and Permeability. *Fluid Dynamic Research*, vol.37, pp. 82-132.

Wang, W. & Parker, K.H. (1995). The effect of deformable porous surface layers on the motion of a sphere in a narrow cylindrical tube. *J. Fluid Mech.*, vol. 283, pp. 287-305.

Zerda, P.R., Chien, S. & Skalak, R. (1977). Interaction of viscous incompressible fluid with an elastic body. *Computational methods for fluid solid interaction problems*, ed. T. Belytschko and T.L. Geers, New York. American Society of Mechanical Engineers, pp. 65-82.

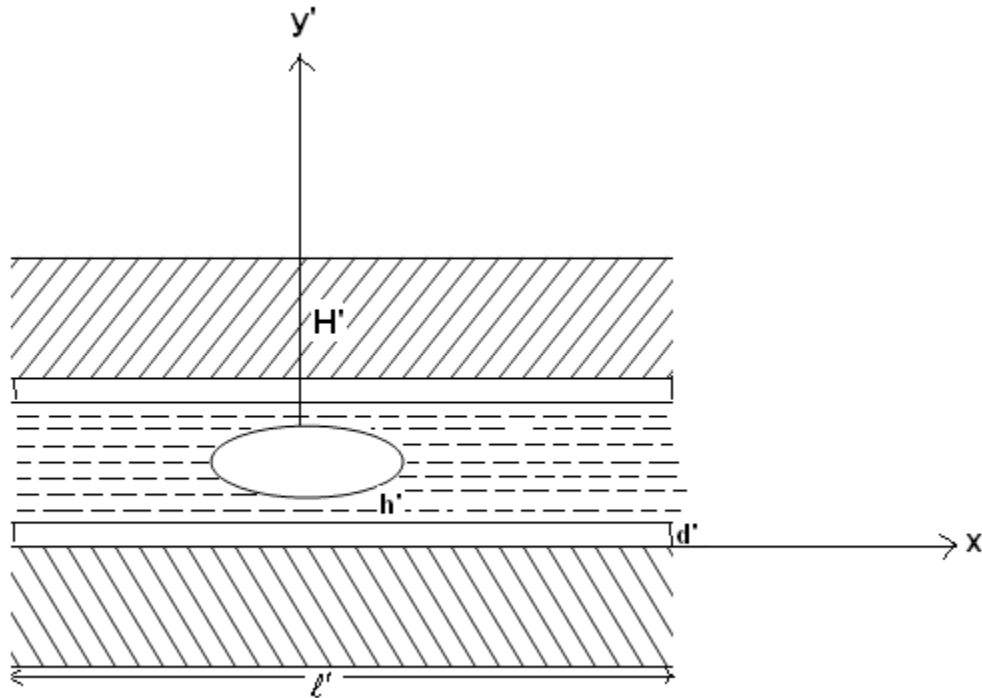

Fig 1

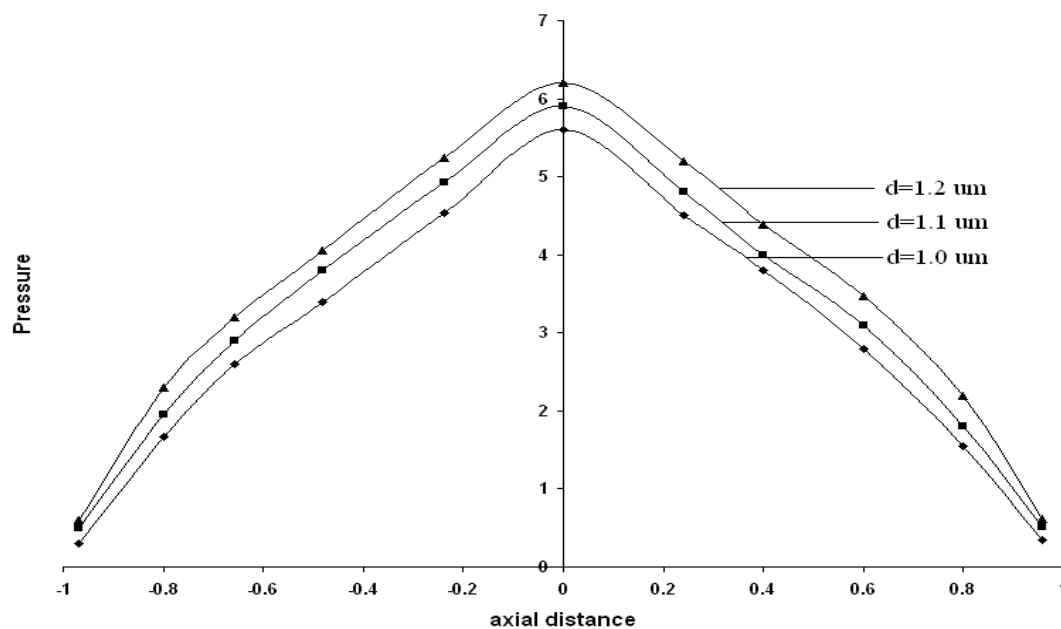

Fig.2 Variation of Pressure with axial distance for different values of glyocalyx thickness

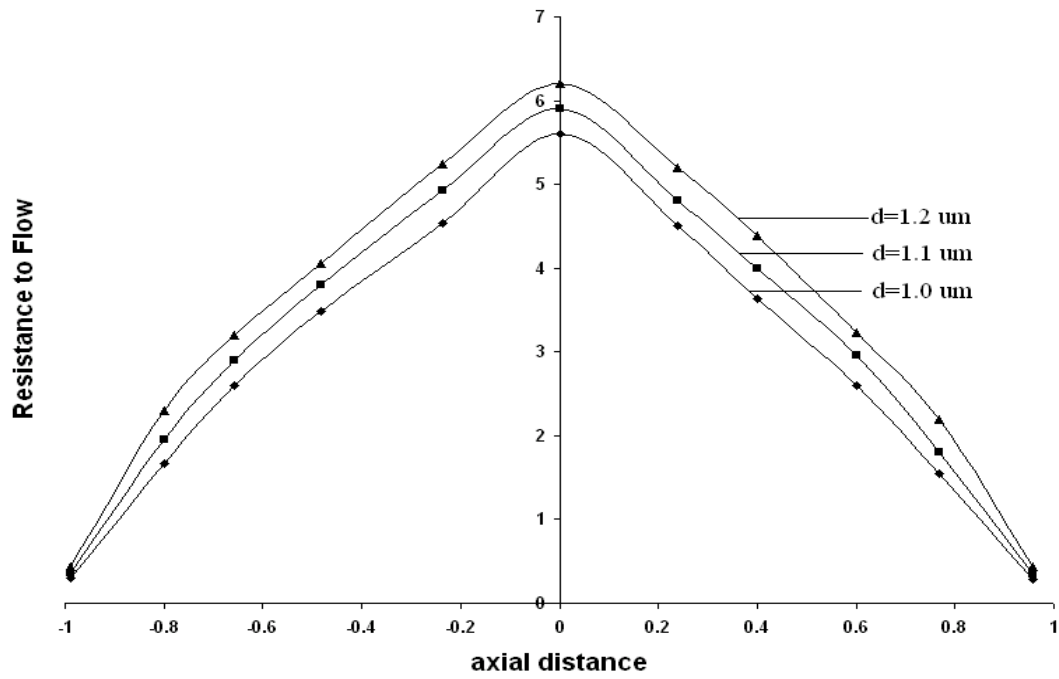

Fig.3 Variation of Resistance to Flow with axial distance for different values of glycolyx thickness

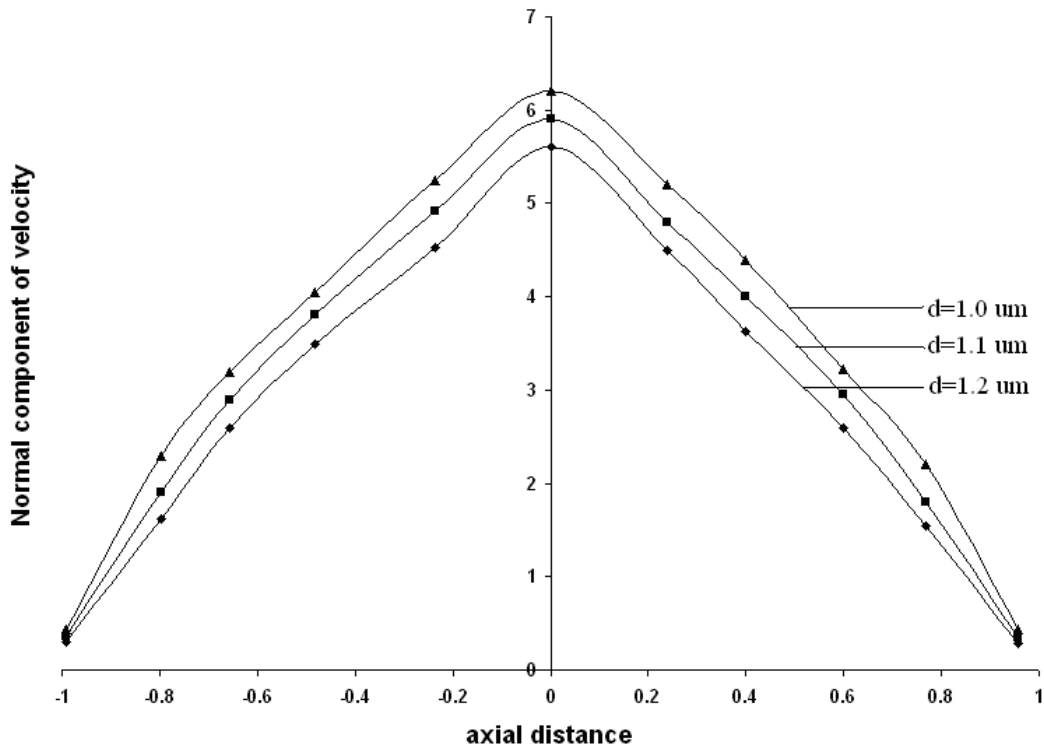

Fig. 4 Variation of Normal component of velocity with axial distance for different values of glycolyx thickness

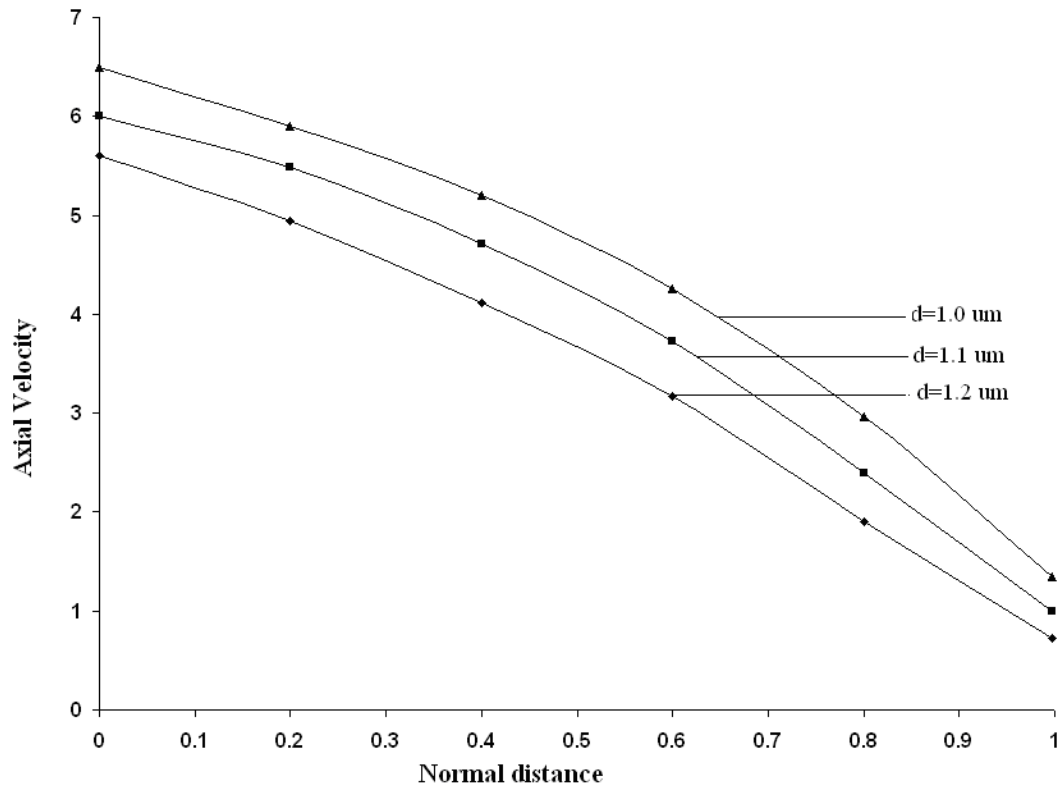

Fig 5. Variation of axial velocity with normal distance for different value of Glycocalyx thickness

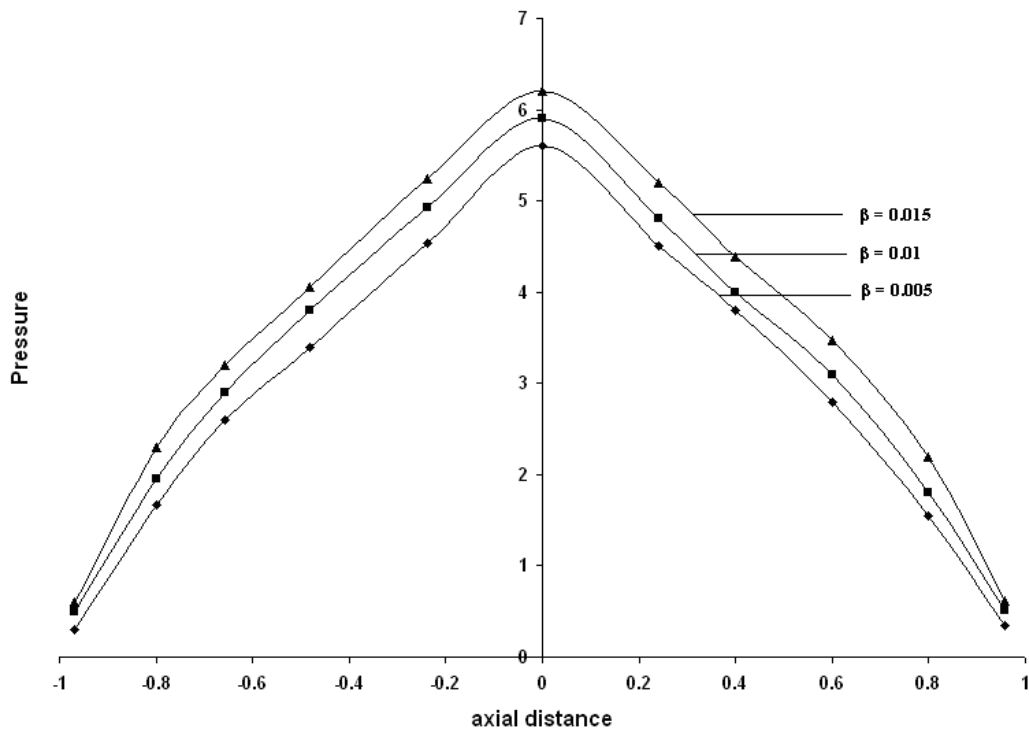

Fig.6 Variation of Pressure with axial distance for different values of cell shape β

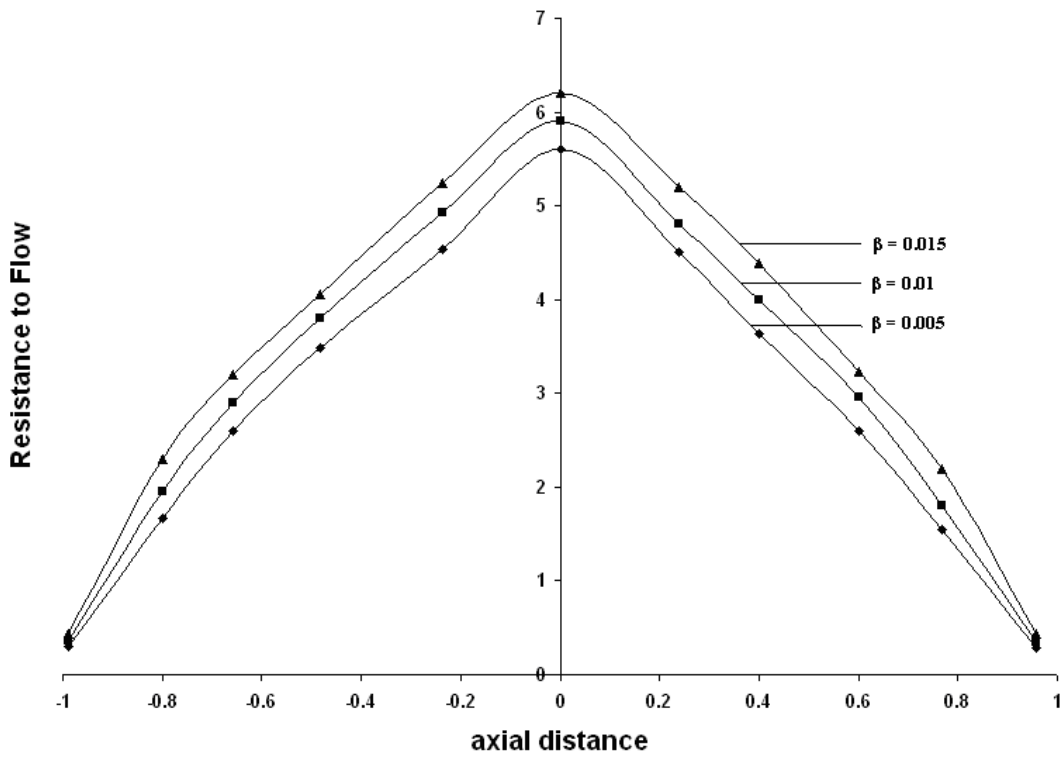

Fig. 7 Variation of Resistance to Flow with axial distance for different values of cell shape β

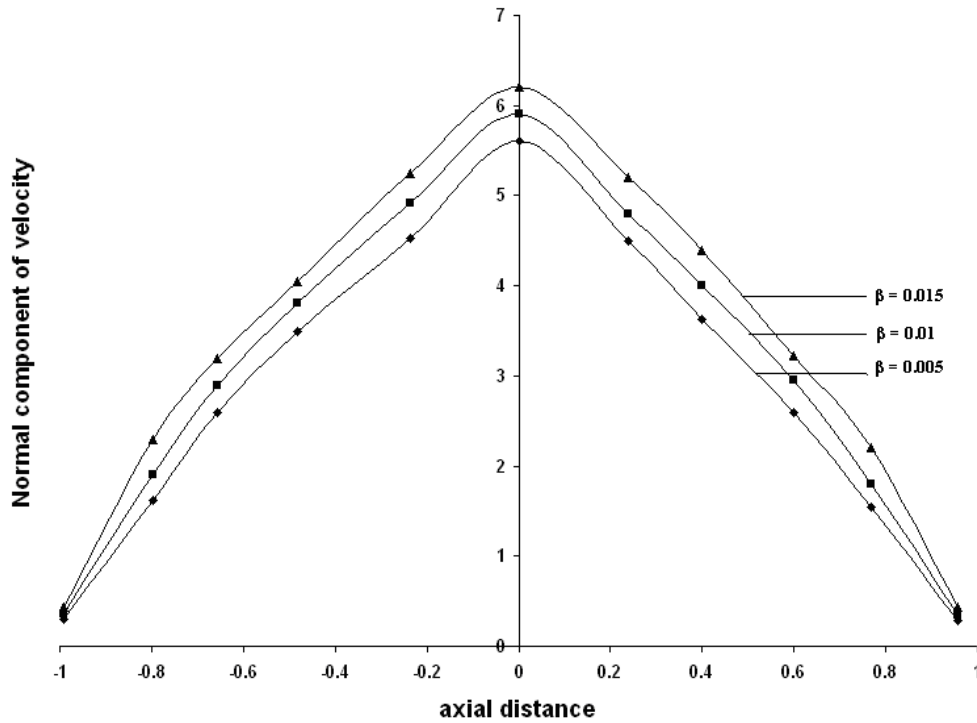

Fig. 8 Variation of Normal component of velocity with axial distance for different values of cell shape β

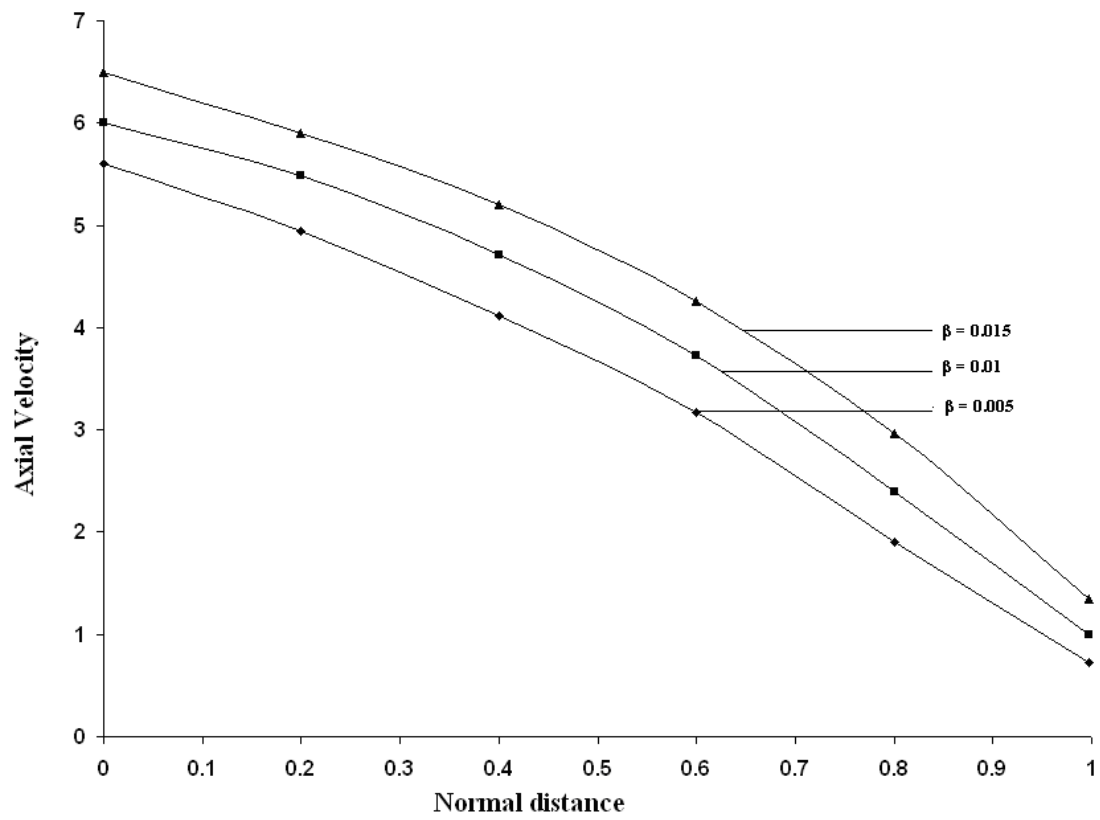

Fig 9. Variation of axial velocity with normal distance for different value of cell shape β